



AUSTRALIA
USA/CANADA

BeefEater SL4000s Series Stainless Steel Barbecues

Assembly And Operating Instructions



For outdoor use only

Certified ISO 9001 : 2000 by



Australia's Leading Barbecue



Safety Warnings

Check Gas Type

Check that the gas type is correct for your type of gas,.
You will find the gas type label on the underside of your side burner. If your side burner is of the incorrect gas type, or if you are unsure, consult your dealer before going any further.



WARNING: We want you to enjoy your barbecuing experience - Failure to follow the instructions and observe the warnings provided in this operating manual could result in serious bodily injury or damage to property.

NOTE TO INSTALLER: This manual must remain with the owner for future reference.

- Some foods produce flammable fats and juices. Regular cleaning is essential.
- Attend an operating barbecue at all times. Damage caused by fat & grease fires is not covered by warranty.
- When not in use keep barbecue and side burner dry and covered.
- Vinyl covers are an optional accessory that will ensure years of trouble free operation.

Warning: If you smell gas, shut off gas supply and extinguish any open flame. If odour continues immediately call your gas supplier.

Caution: Electrical Warning

If your barbecue incorporates an electrical component, such as a rotisserie, then it must be electrically grounded in accordance with local codes. The electric cord must be equipped with a three-prong (grounding) plug for your protection against shock hazard and should be plugged directly into a properly grounded three-prong receptacle. Do not cut or remove the grounding prong from this plug. Keep any electrical supply cord and the fuel supply hose away from any heated surfaces.

If an external electrical source is utilised, this outdoor cooking appliance, when installed, must be electrically grounded in accordance with the local codes or, in the absence of local codes with the following:

USA: National Electrical Code, ANSI/NFPA 70

CAN: Canadian Electrical Code, CSA C22.1

AUS: Aust Standards Code AS:5601

Warning: Contact your local municipality for any building codes regulating the installation of outdoor barbecue appliances. Outdoor installations must conform to local codes or, in the absence of local codes, with the following:

USA: National Fuel Gas Code, ANSI Z223.1/NFPA 54

CAN: B149.1 Natural Gas & Propane Installation Code.

AUST: Australian Standards Code AS: 5601

as well as the requirements of any local council, gas, electricity authority or other statutory regulation.

When using an LPG supply system in an enclosure, ventilation must be provided. Gas vapour is highly explosive and can cause serious bodily injury or damage to property if allowed to accumulate in a confined space and ignited.

This appliance must not be installed under or on any combustible material. Minimum clearance from combustible materials to all sides of the appliance is 450mm (18").

These specifications must be left with the owner.

This appliance must be installed in accordance with the installation requirements of the LOCAL GAS and ELECTRICITY supply authority, or the appropriate installation code issued by Standards Australia.

USA

Fuels used in gas or oil-fired appliances, and the products of combustion of such fuels, contain chemicals known to the state of California to cause cancer, birth defects and / or other reproductive harm. This warning is issued pursuant to the California Health & Safety Code Sec. 25249.6.

The Gas cylinder must be constructed and marked in accordance with specifications for LP Gas Cylinders of U.S. Dept. of Transportation (DOT) or the National Standard of Canada, CAN/CSA - B339, Cylinders, Spheres or Tubes for the transportation of dangerous goods.

The gas cylinder used must incorporate a safety collar to protect the valve assembly. The gas cylinder supply valve must be turned off when the appliance is not in use.



DO NOT

- Lean over barbecue when lighting.
 - Leave cooking food unattended.
 - Delay lighting burners after turning gas on.
 - Spray or store aerosols in vicinity of barbecue whilst in operation.
 - Store combustible materials, gasoline or flammable liquids or vapours within 450mm (18") of barbecue.
 - Use caustic based cleaning agents on the barbecue.
 - Operate barbecue with any cover on.
 - Use plastic or glass utensils on the barbecue.
 - Operate barbecue in strong winds.
 - Attempt to dismantle control valves.
 - Attempt to dismantle or adjust regulator.
 - Test for gas leaks with a naked flame.
 - Store gas cylinder indoors, or in any enclosed area.
 - Lay the gas cylinder down. (Always keep it upright)
 - Use barbecue indoors.
 - Expose hose to direct sunlight.
 - Modify the construction of this appliance or the size of any burner or valve orifice .
 - Move the appliance during use.
 - Obstruct any ventilation of barbecue or the cylinder.
 - Allow the flexible gas supply hose or any electrical cord to come in contact with any heated surface of the appliance.
 - Allow children to operate this appliance.
 - Operate Window - Roasting Hoods in the rain.
 - Use charcoal or any other solid fuel in this appliance.
 - Disconnect any gas fittings while the appliance is operating.
 - Use a rusty or dented gas cylinder or cylinder with a damaged gas valve.
 - Fill the gas cylinder beyond 80% capacity.
 - Smoke or use a naked flame near the gas cylinder while disconnecting the gas line between the appliance and gas cylinder.
- Should the appliance go out for any reason, turn off all control knobs and the cylinder gas valve. Wait 5 minutes before attempting to relight the appliance.
 - If a grease or fat fire should occur, immediately turn off all control knobs and the gas cylinder valve until the fire is out. Remove all food from the appliance.
 - A leak test must be carried out prior to using the appliance for the first time and whenever the gas cylinder is refilled or whenever the gas hose and regulator have been disconnected from the gas cylinder or appliance.

DO

- Spanner tighten all gas fittings as per instructions.
- Check all gas hoses and line connections for damage, cuts or cracks each time the appliance is to be used.
- Always Leak - test with a solution of soapy water.
- Check main opening, throat and venturi to each burner and pilot flame tube regularly for insect nests (eg. wasp, ants or spiders). Nests are dangerous and must be cleaned out thoroughly.
- Visually check burner flames to confirm lighting.
- Clean glass window of roasting hood model regularly.
- Use your barbecue only on a level surface.
- Attend barbecue whilst cooking food.
- Preheat the barbecue for up to 10 minutes.
- After cooking turn barbecue to high for up to 10 minutes to burn off excess grease.
- Let the barbecue cool before replacing any lid or cover.
- Regularly replace foil material in Grease/Drip tray.
- Keep children away from barbecue at all times. Accessible parts may be hot.
- Have the gas cylinder filled by an authorised LPG supplier.
- Refer to this instruction manual if in doubt concerning assembly, installation, or operation.
- Use protective gloves when handling hot components.
- Close the gas cylinder valve after each use.
- Clean the Grease/Drip tray regularly and clean the appliance at least twice annually.
- Always fully open the roasting hood or remove the metal lid of the appliance before lighting.
- Carefully follow the instructions relating to the hose/regulator connection.
- Keep the barbecue area free from combustible materials, gasoline, flammable liquids or vapours.



Assembly Of Main Barbecue

Before You Start

Note the tools you will need before you begin.

Remove any protective plastic from stainless steel components.

Check for damaged or missing parts, and consult your retailer if necessary.

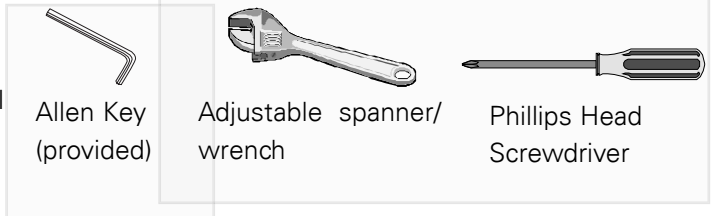

Attach the Side Shelves

Attach the side shelves to the top of the cart using the four screws provided with each side shelf kit. You do not need any nuts, as the screws go directly into threaded holes in the cart.

If you have an optional lower side shelf, attach it to the side panel using 4 screws and nuts.

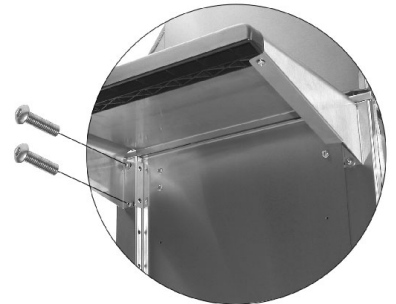

Top side shelf - use the front holes, screws only

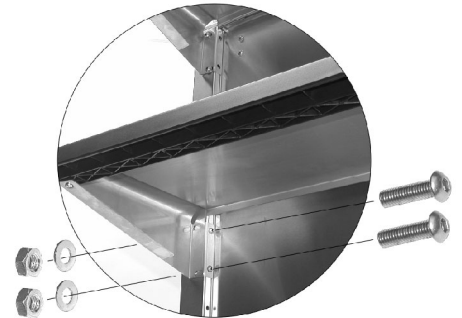

Lower side shelf - use the side holes, screws, washers and nuts.

Side Burner Trivet

Assemble the side burner parts as shown.

The first burner disk should locate onto two notches on the side burner.

Also, the two notches on the bottom of the trivet line up with the holes on the side burner.

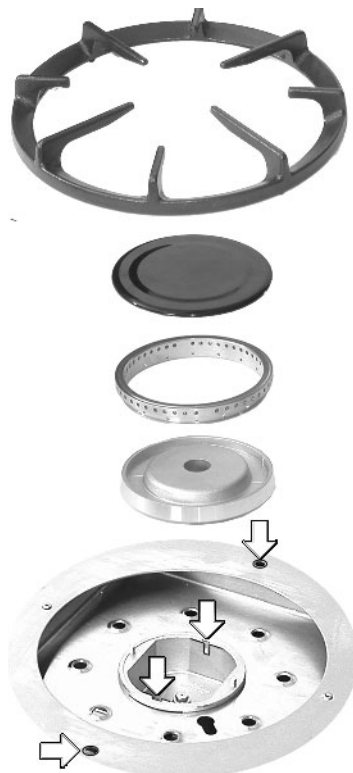



Assembly Of Main Barbecue

Fit The Heat Reflectors

The reflectors fit between each burner. They reflect heat from the burners, upwards to the cooking surfaces.

The tabbed ends of the heat reflectors face forward to the front of the barbecue frame. The tabs fit into the slots in the front end of the barbecue behind the control panel.

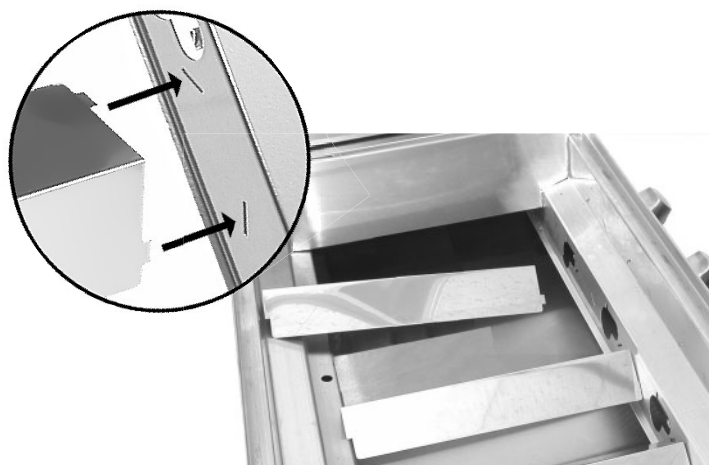

Fit The Burners

Remove the 'R'-shaped retaining clips from the burners.

Fit the burners, open end first, over the stem of the control valves at the front of the barbecue. Lower the other end of the burner so the lug locates into the corresponding hole at the rear of the barbecue.

Replace the retaining clips into the burner lugs so the burners stay in position.

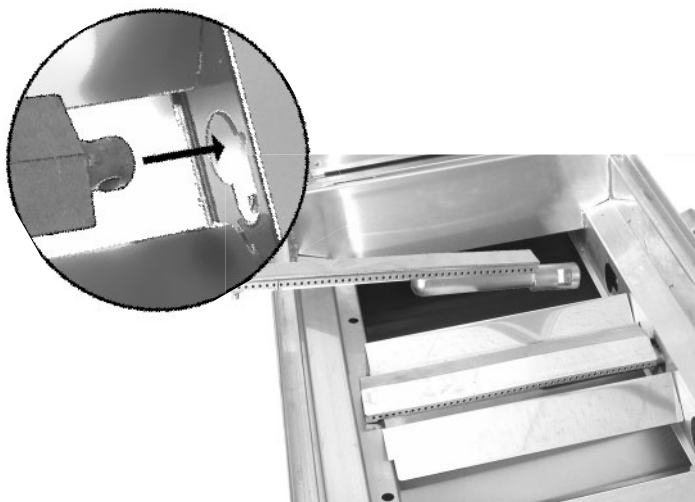

Fit The Vaporizers

The Vaporizers are designed to vaporise fats and juices from the meat. One Vaporizer is fitted over each burner that is located under the grill. The Vaporizers reduce flare-ups and help to add that great barbecue flavour.

The tabbed ends of the Vaporizers face forward to the front of the barbecue frame. The tabs fit into the slots in the front end of the barbecue behind the control panel. The Vaporizers should be fitted to the same side of the barbecue as the grate. They will not work if fitted under the plate.

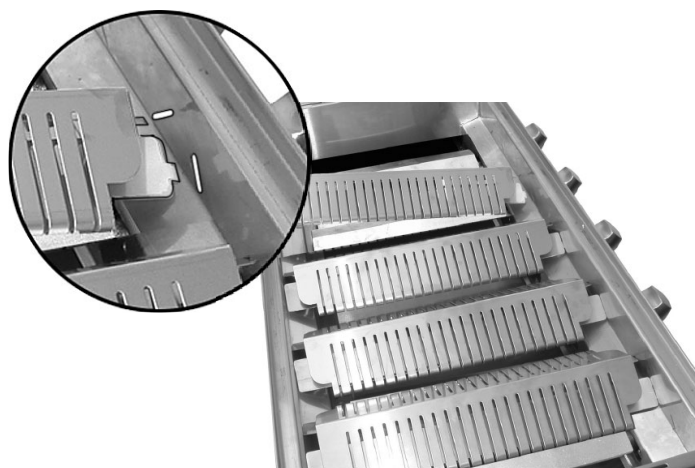



Assembly Of Main Barbecue

Fit Cooking Plates And Grates

We recommend fitting the plate to the left-hand side of the barbecue frame (with the drain hole to the extreme left). The grates can be fitted to the right hand side of the barbecue frame. The grates must always be positioned over the Vaporizers.

The 4+1 burner model comes standard with a 320mm plate, a 330mm grill and a 161mm grill. You may use other combinations of cooking surface, however, the plate may cover no more than 50% of the total cooking area .

The 5+1 burner model comes standard with one third plate and one two thirds gate and are approved for use with a maximum of two thirds plate.

Do not cover the entire surface of the barbecue frame with plates as this will cause severe heat damage to the appliance.

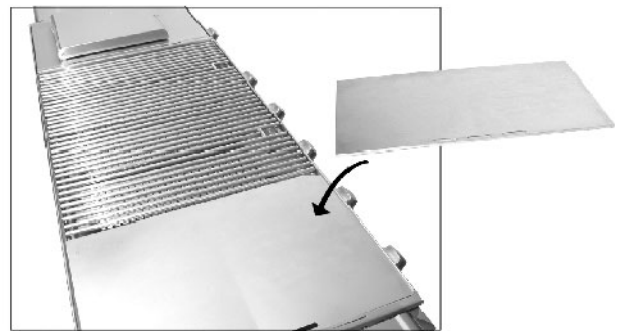
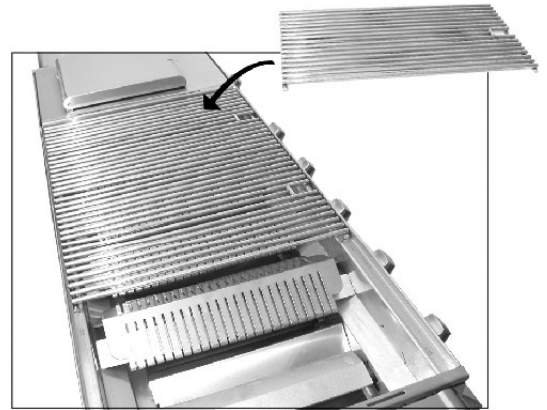

Fit The Warming Rack

The warming rack needs no screws. It sits on two notches on the insides of the hood.

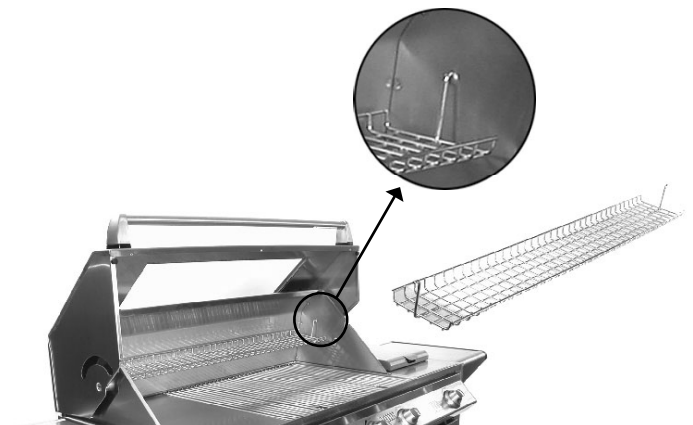



Assembly Of Rotisserie

Assemble The Main Shaft

Assemble the shaft in the order shown.



The knurled nut, counterbalance and handle go on the threaded end.



Slide the collar down towards the handle end.

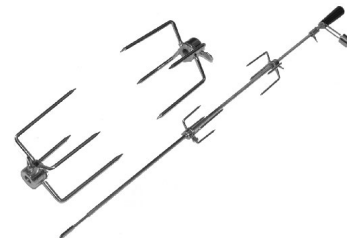

Slide the prongs onto the shaft so they face each other.

Fit The Motor

First attach the motor mounting bracket to the roasting hood.

Then slide the motor onto the bracket.

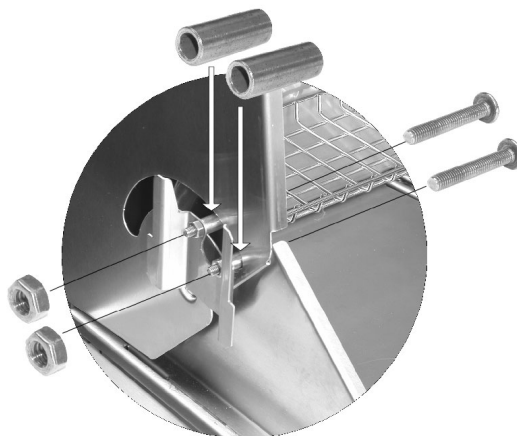

Fit The Shaft

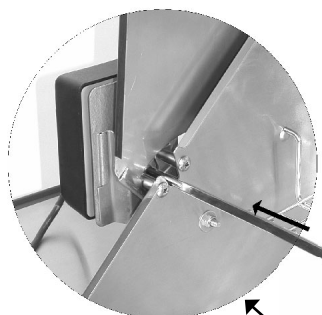

The pointed end goes into the motor

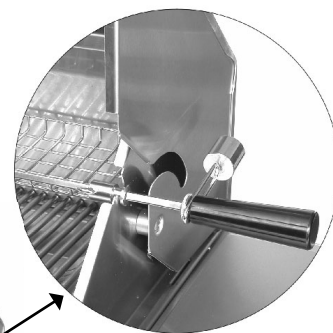

The collar rests on the roasting hood.



Assembly Of Accessories

Fit the Baskets

The storage racks and condiment baskets can be fitted directly, without the use of screws. Ensure they locate properly into their respective holes.

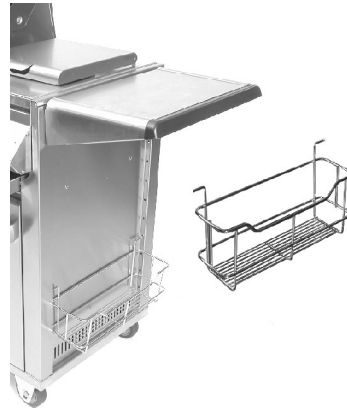

External storage baskets slot into the holes in the side panel, either left or right.

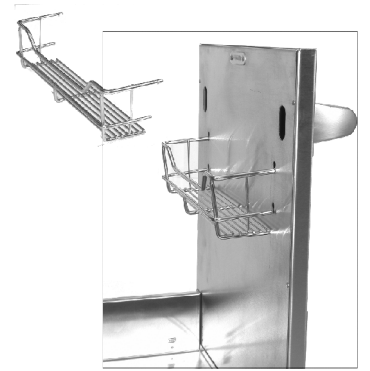

Internal condiment racks fit inside the middle and left hand drawers.

Fit the towel rack

First, unscrew and remove the plastic end caps from the towel rack. Then, using 2 flathead screws, washers and nuts, attach the towel rack to the side panel. You may need to slide the towel rails out of the way to access the screw holes.



Fit the Drawer Accessories



Waste Bin



Ice Bucket

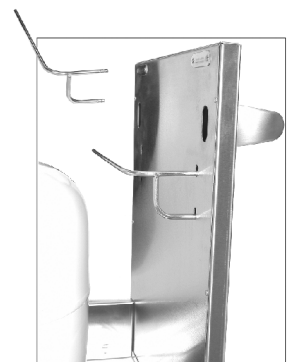

Paper Towel Holder



Installation

LPG/Propane Cylinder

If your barbecue is to be connected to a portable LPG cylinder, you should position it in the far right drawer. Place the prefitted mat down first, then position the cylinder on top. Secure the cylinder by wrapping the strap around the cylinder and clipping it to the bracket slots highlighted in the illustration.

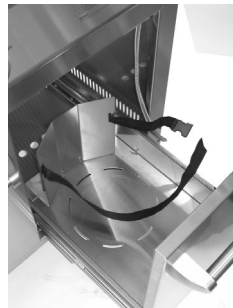

Where To Put Your Barbecue

It is important that your barbecue is placed above ground, in an open air situation where there is adequate natural ventilation, without stagnant areas, so that as the gas burns, the combustion gases are dispersed by wind and natural convection. Barbecue enclosures must comply with the following:

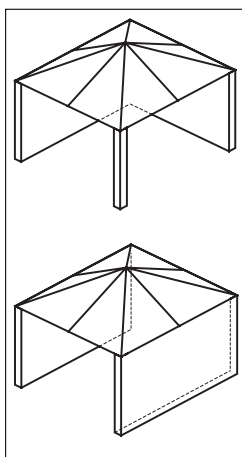

The barbecue may be within a partial enclosure that includes an overhead cover and no more than two walls.

A common example is an outdoor gazebo.

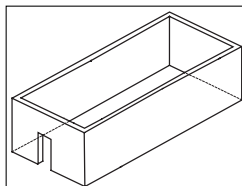

An enclosure with walls on all sides, but at least one opening at ground level, and no overhead cover.

A common example is an enclosed back yard. Typically, the walls are less than 3m high. If they are higher, there is a danger of gas build up.

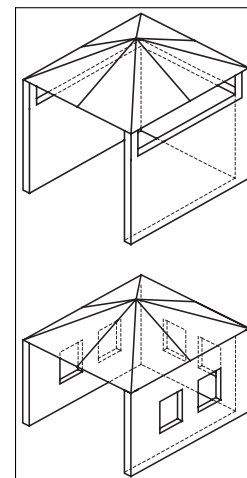

The barbecue may be within a partial enclosure that includes an overhead cover and more than two walls, as long as:

- At least 25% of the total wall area is completely open, and
- at least 30 percent of the remaining wall area is open and unrestricted.

With balconies, at least 20% of the total of the side, back and front wall areas shall be and remain open and unrestricted.



Installation

Before You Begin

If you have not done so already, check the gas type label as described on page 2.

This appliance must have a minimum clearance from combustible materials of all sides of the barbecue of 450 mm.

Do not install the appliance under or on any combustible surface.

The appliance must be tested for safe and proper operation on completion of installation.

Keep ventilation openings in the lower cabinet clear and free of any debris.

This barbecue is not approved for use on marine craft.

Mobile Installation - Portable LP Gas/Propane

Recommended minimum LPG cylinder capacity for use with this appliance is 4kg. Maximum LPG cylinder capacity for use with this appliance is 10kg. In the USA, only a 20lb cylinder may be used.

Fit the regulator to the LPG cylinder, as shown on the right.

Secure all joints spanner (wrench) tight but do not over-tighten.



For POL cylinders, tighten counter-clockwise



For Quick Connect cylinders, tighten clockwise

Fixed Installation - Portable LP Gas/Propane.

BeefEater propane barbecues are designed to operate at 2.75Kpa (11"WC).

Connect the gas supply line to the barbecue inlet located on the right side of the appliance using either hard plumbing, or a flexible hose connected to a bayonet point. Refer to AS 5601 or your local installation code for pipe sizing details. Secure all joints spanner tight but do not over-tighten.

Test gas pressure by removing the last burner from the left hand side of the barbecue and attaching a hose and pressure gauge to the end of the gas valve. Turn on 2 burners and check the pressure. Inlet pressure should be 11.0" WC or 2.75 kPa.

For mobile trolley installations that use flexible hosing to connect to natural gas, a chain or similar restraining device must be fitted to prevent strain on the gas supply line. One end of the chain should attach to the barbecue; the other end should attach to a fixed structural point close to where the hose connects to the gas piping. The chain must be at least 30% shorter than the gas supply line. In this way, if the barbecue is accidentally moved, the chain stops the barbecue from stretching the hose.



Installation

Fixed Installation - Natural Gas

(Natural Gas installation should be carried out by a qualified gas fitter)

BeefEater Natural Gas barbecues are designed as low- pressure appliances (4.0" WC, 1.00KPa).

Fit the natural gas regulator supplied directly to the barbecue inlet located on the right side of the appliance using either hard plumbing, or a flexible hose connected to a bayonet point. Refer to AS 5601 or your local installation code for pipe sizing details. Secure all joints spanner tight but do not over-tighten.

Test gas pressure by removing the last burner from the left hand side of the barbecue and attaching a hose and pressure gauge to the end of the gas valve. Turn on 2 burners and check the pressure. Inlet pressure should be 4.0" WC or 1.00 kPa.

For mobile trolley installations that use flexible hosing to connect to natural gas, a chain or similar restraining device must be fitted to prevent strain on the gas supply line. One end of the chain should attach to the barbecue; the other end should attach to a fixed structural point close to where the hose connects to the gas piping. The chain must be at least 30% shorter than the gas supply line. In this way, if the barbecue is accidentally moved, the chain stops the barbecue from stretching the hose.

The barbecue appliance must be isolated from the gas supply piping system by closing its manual shutoff valve during any pressure testing of the gas supply piping system.

Secure All Joints And Leak Test

Never use a naked flame to check for gas leaks. The gas leak testing procedure should be conducted every time a gas cylinder is refilled and reconnected to the appliance, or after any new gas connection is made.

In a small container, mix up a solution of water and detergent or soap. Mix the solution well.

For LPG make sure that the gas supply valve on the gas cylinder is turned on.

For Natural Gas make sure that the gas shutoff valve is on.

Make sure that the gas control valves on the appliance are all turned off.

Using a brush or spray bottle apply the solution to the gas line and each joint in the gas line.

Bubbling of the solution will indicate that there is a leak present.

Re-tighten or re-seal any joints that are leaking.

If a leak persists contact your distributor or the manufacturer for assistance.

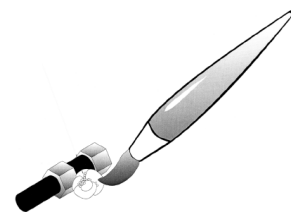

Check Proper Burner Operation

Following operating instructions light each burner and check for a clear blue flame with just a tip of yellow.

Excess yellow tipping can be adjusted using the screw the screw on the side of the burner. Turn the screw in an anti-clockwise rotation to remove the yellow.

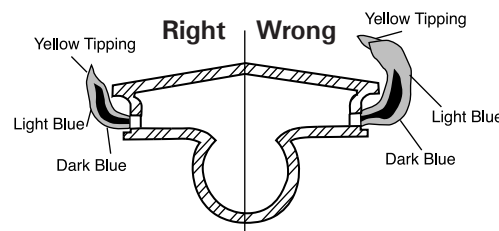



Using Your Barbecue

Before You Light The Barbecue

Perform the following checks

- Make sure all gas connections are tight and leak tested.
- Ensure the cooking surfaces are clean and hygienic
- Check the control knobs are on the off position
- Check that the gas supply is turned on
- Ensure the hood of the barbecue and the lid of the side burner are up. If you do not, gases can build up inside the hood and create a dangerous situation.
- Make sure long handles do not hang over the edge of the barbecue. Injury can result if they are accidentally knocked.

Fat Tray

Neatly line the drip tray with a couple of sheets of aluminium foil to aid in clean up . Cut the foil to shape and make sure that the foil sits on the bottom of the tray

Fill the tray with a 6mm (1/4") layer of dry sand or other non-combustible absorbent material to absorb grease. Change the foil and absorbent material regularly to reduce the likelihood of a drip tray fire

Lighting The Barbecue

Your barbecue is equipped with safety a safety feature that prevents them from being accidentally knocked out of the OFF position. The same procedure is used to light the main burners as well as the side burner:

1. Push in and hold the control knob down while turning slowly in an anti clockwise direction until the starter mechanism engages at the two o'clock position. At this time the gas will start to flow.
2. Hold the control knob in while continuing to turn the knob toward the High or twelve o'clock position.
3. The starter mechanism will click and the main burner will now light. Continue turning the knob slowly until it rests in the twelve o'clock position.

If the burner is alight, release the knob.

If the burner does not light

Keep the control knob pushed in and turn the control knob in a clockwise direction to return to the OFF position. Wait 5 minutes for the gas to disperse and then repeat steps 1-3. If you cannot light the burners, call your retailer before proceeding.

Manual Lighting

Press and turn the "LEFT Hand" control knob anti-clockwise to the "HIGH" position, then light the left hand burner immediately through the gap between the front of the drip tray and the barbecue body.

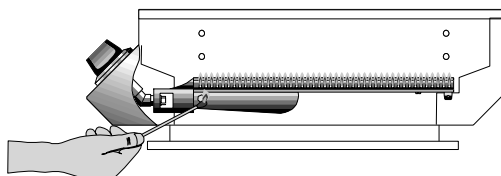

Off - Knob points to right.



High - press in and turn so knob points up



Low - continue turning so knob points to left



Using Your Barbecue

Controlling The Burners

The control knob can now be turned to the desired heat setting, Low, Medium or High. The control knob does not need to be pushed in while selecting the heat setting.

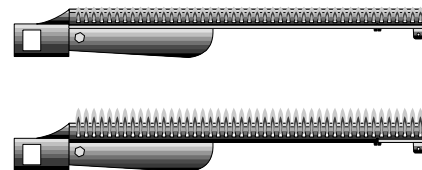

To Turn Off The Burner

Push in and hold the control knob while turning in a clockwise direction until the off position is reached.

After Use

It is a good idea to leave the barbecue on for about 10 minutes after you have finished cooking. This helps to burn away any excess food residues and oil, and makes cleaning easier.

1. Be sure to turn off all control knobs and cylinder valve (for Propane - LPG) or shut-off valve (for Natural Gas).
2. Allow barbecue to cool.
3. Clean the drip tray and cooking surfaces.
4. Clean any food spills from the side burner.
5. Lower the hood and side burner lid,

Remove the gas cylinder from the enclosure before disconnecting the gas line from the appliance.

Tighten all connections before placing the gas cylinder back in its enclosure.

How Long Will The Gas In My Cylinder Last?

If you have a full cylinder of propane, just look at the table below to see how many hours of gas you have, depending on how many burners you have alight. These figures are approximate only.

You may notice that if you have several burners alight and your cylinder becomes low on gas, the liquid may freeze up. If this occurs, turn the cylinder and all burners off and wait till the liquid thaws. You may then reignite the burners.

	9 kg/20lb bottle		4 kg/9lb bottle	
	High	Low	High	Low
1 burner	25 hours	75 hours	11 hours	33 hours
2 burners	12.5 hours	37.5 hours	5.5 hours	17 hours
3 burners	8.3 hours	25 hours	3.7 hours	11 hours
4 burners	6.3 hours	19 hours	2.75 hours	8 hours
5 burners	5 hours	15 hours	2.25 hours	6.6 hours

These tables were worked out using the following:

- ★ Each burner on high setting uses 19 MJ/hour or 18,000 BTU/hour
- ★ Each burner on low setting uses 6 MJ/hour or 5,700 BTU/hr
- ★ Each kg of gas contains 50MJ. Each lb of gas contains 21,600 BTU



Getting The Most From Your Barbecue

Preheating Your Barbecue

Like an oven, preheating your barbecue before cooking produces better results. Because your hood retains heat so efficiently, preheating your barbecue is quicker with the hood down.

Turn the outside two burners to high. Close the hood, and allow to preheat for about 8 minutes. Then reduce the burner settings to achieve and maintain the required temperature, by following these guidelines.

Maintaining The Right Cooking Temperature

These two charts tell you how hot and how long to cook various types of meat, and the approximate burner settings to help you achieve these results.

As you can expect, there are many variables involved. A little experience is all you'll need to feel perfectly comfortable and in control of your barbecue.

Two burner	Both burners slightly below medium
Three burner	Middle burner off Two outside burners to medium
Four burner	Two inside burners off Two outside burners to medium
Five burner	Three inside burners off One outside burner to high Other outside burner to medium

Type of Meat	Cooking Temperature	Approximate Cooking Times	
		per kg	per lb
Beef	180°C / 355°F	45-55 min	20-25 min
Lamb	180°C / 355°F	45-55 min	20-25 min
Pork	170°C / 340°F	55-60 min	25-30 min
Veal	160°C / 320°F	40-50 min	18-23 min
Poultry	180°C / 355°F	40-50 min	18-23 min
Seafood	150°C / 300°F	20-30 min	9-14 min

You may find it useful to purchase a meat thermometer to help take the guess work out of cooking.

Meats such as beef, lamb, veal and pork should be about 70°C/160°F when medium. Chicken and Turkey should be 85-90°C/185-195°F.

Most importantly, do not allow your barbecue to overheat. Your hood is designed to keep the heat in, and so requires constant monitoring.

Do not use more than 2 burners on high at any one time. As a guide, for a 4 burner barbecue in moderate weather:

- Two burners on low produces 150°C/300°F
- Two burners on medium produces 195°C/385°F
- Two burners on high produces 240°C/460°F

During cold or windy conditions, more heat is required.

Finally, resist the temptation to keep opening the hood while cooking. This will help to maintain a constant temperature, and minimise cooking time.

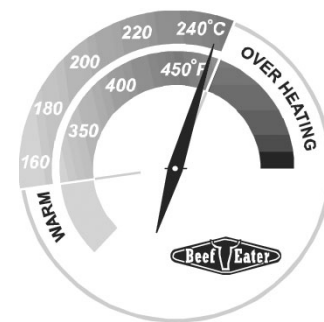

Do not allow your barbecue to overheat, as this may damage some components.



Getting The Most From Your Barbecue

Direct Cooking Method

Commonly used for traditional barbecuing. Place food over the lit grill section. Excess flaring may occur and so care must be taken while cooking. Check inside the roasting hood regularly. We do not recommend this method for roasts unless you place a baking dish under the roast, this will allow flammable fats and juices to be isolated away from the flame. The direct cooking method is recommended for steaks, chops, sausages, and hamburgers.

Indirect Cooking

Indirect cooking involves little or no heat directly underneath the food. Instead, the food is placed on the grill, the burners below the food are turned off, and burners on either side are used. With this method, heat circulates around the food, cooking by convection.

By trapping the vapour inside your "outdoor oven," the cooking vapour will fall back on the food on all sides, not just from underneath. The food cooks more evenly, and stays moist in the process.

This method of cooking applies only if you have a roasting hood.

Indirect cooking is similar to using a conventional oven and is recommended for rotisserie cooking, roasts, poultry, casseroles, vegetables and whole fish.

Using The Rotisserie

The rotisserie provides an excellent means of cooking large cuts of meat slowly and evenly all round.

The rotisserie shaft should pierce the food as close to the middle as possible. However, occasionally there will be more weight on one side of the shaft than the other. If left like this, it will cause a strain on the rotisserie motor.

Use the counterweight to adjust the balance on the rotisserie. Loosen the handle slightly, and adjust the position of the counterweight until it is opposite the heaviest portion of the meat. Retighten the handle. It is a good idea to spin the rotisserie by hand before connecting it to the motor to see if it has been successfully balanced.

Using The Side Burner

The side burner allows you to par boil sausages, stir fry, prepare sauces, or precook vegetables without leaving your barbecue.

You turn the side burner on the same way you turn your barbecue on.

Ensure that long handles do not hang too far over the edge of the burner, as this can create a safety hazard.



Cleaning Your Barbecue

Stainless Steel Grills

Many food acids, marinades, juices and sauces contain highly acidic elements that will slowly attack the surface of the stainless steel if not removed immediately after cooking.

- After use, remove all solid material from the cooking surfaces using a brass bristle brush or plastic scourer. Brushes specifically designed for this purpose can be purchased from your BeefEater retailer. Wipe off remaining residue with a paper towel.
- Gently wash the surface of the grills with a soft sponge and a solution of hot water and a mild dishwashing liquid. Do not use highly caustic, harsh or abrasive chemical cleaners to clean the cooking grills. (Always check the manufacturer's recommendations for the cleaner prior to use.)

Before each subsequent use, pre-heat your BeefEater for 10 minutes before cooking.

Drip Tray

Replace aluminium foil or absorbent material in drip tray at regular intervals to prevent grease build-up, which could result in a grease fire and void the barbecue warranty.

Burners

- Check main opening, throat and venturi to each burner regularly for insect nests (eg. wasp, ants or spiders). Nests are dangerous and must be cleaned out thoroughly.
- Remove burners periodically and scrub clean with soapy water and a wire brush making sure that the ports are free of obstructions. Replace burners in the correct position and dry by lighting each one to avoid subsequent corrosion.

Stainless Steel Barbecue and Cart Panels

After the appliance has been used, wash down the surfaces with hot soapy water. Avoid abrasive cleaners or brushes as these could damage the surface and graphics, especially on the control panel.

The surface of the stainless steel has a grain. Always clean in straight lines along the grain of the steel and avoid scratching. Do not use steel wool.

Near the ocean or salt-water environment, wash regularly, rinse and then dry before covering. Covering a salt sprayed stainless steel product while still wet will allow salt deposits to form, causing rust to form even on very high grade Stainless.

Discoloration of Stainless Steel

Discoloration of stainless steel, caused by high heat is known as 'Chromium Oxide' and sometimes appears as a light brown colouring over the surface of the steel. In most cases, this discoloration can be removed with a suitable stainless steel polish. Note: Discoloration of the Stainless steel is not covered under warranty.

To Remove The Hood For Cleaning

To remove the hood, first disconnect and remove the rotisserie and warming rack.

The hood connects to the barbecue using four tabs. To remove the hood, slide it back along the barbecue, and carefully tilt it forward until the tabs disengage from the slots.





Cleaning Your Barbecue

To Remove The Fat Tray For Cleaning

The fat tray is held to the runners using four tabs as shown. To release the tray, pull the tray over the tabs at each of the four points.

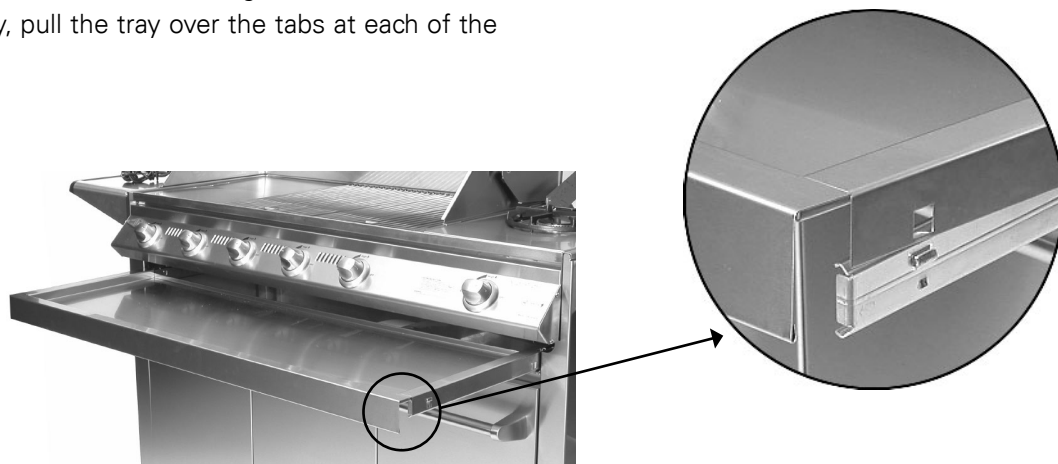

Storing Your Barbecue

When storing barbecue for extended periods, be certain all controls and cylinder valves are turned off.

If storing the barbecue indoors remove gas cylinder and store the cylinder in a ventilated area outdoors.

Gas cylinders must be stored outdoors, out of reach of children and must not be stored in a building, garage or any other enclosed area.

The barbecue should be covered when not in use. eg a polyester or vinyl barbecue cover.

Service And Maintenance

This appliance should be checked and serviced by an authorised service person every 2 years to ensure the appliance remains in a safe operating condition. (These services are not covered by warranty). Spare parts are available from your retailer or the manufacturer.

	Each use	Every 6 months	By authorised service agent every 2 years
Check all hoses for cracks and leaks	✓		
Check that all gas connections are tight	✓		
Clean entire barbecue thoroughly		✓	
Check and tighten all bolts on barbecue and cart		✓	
Clean and inspect Vaporizers and reflectors		✓	
Clean and inspect barbecue burners		✓	
Clean and inspect gas injectors and control valves			✓
Check working of ignition system			✓



Trouble Shooting Guide

Problem	Cause	Check
Barbecue will not light	Ignition system not working	Check that there is a visible flame coming from the pilot ignition tube. Check that the pilot ignition tube is not blocked by spider webs or insect nests.
	Turning on gas control too quickly	Allow 5 seconds for gas to flow through burner before ignition
	No gas flow	Check that valve on gas cylinder is turned on. Check that burner ports are free of obstructions Check that all gas injectors are clean and free of obstructions
	Burners not assembled correctly	Check that burners are correctly positioned in the barbecue frame.
	Burner ports or throat blocked	Check that the burner ports are not blocked by spider webs or insect nests. Clean out as required
Barbecue lights but goes out soon after starting	Fuel supply turned off	Turn on gas valve at cylinder (LPG/Propane) or shutoff valve on gas line (NG)
	Gas cylinder low or empty	Refill cylinder with gas (LPG/Propane)
	Kink in gas hose	Check that the gas line is not kinked or twisted
	Wind or breeze affecting operation	Ensure that the appliance is located out of the way of wind
Burners will not cross light from one to the other		Check that cross light channel is in place Check that burner ports are free of obstructions.
Low flame level or low heat output		Check you are running on correct gas (NG or LPG/Propane) Check gas injector size is correct
Stainless steel discolours	Overheating appliance	Do not exceed maximum operating temperatures.

Technical Specifications

Gas	Injector size	Input/burner	Gas Pressure
LPG/Propane	1.27 mm	19 MJ/hr	2.75 kPa / 11" WC
Natural Gas	2.1 mm	19 MJ/hr	1 kPa / 4"WC

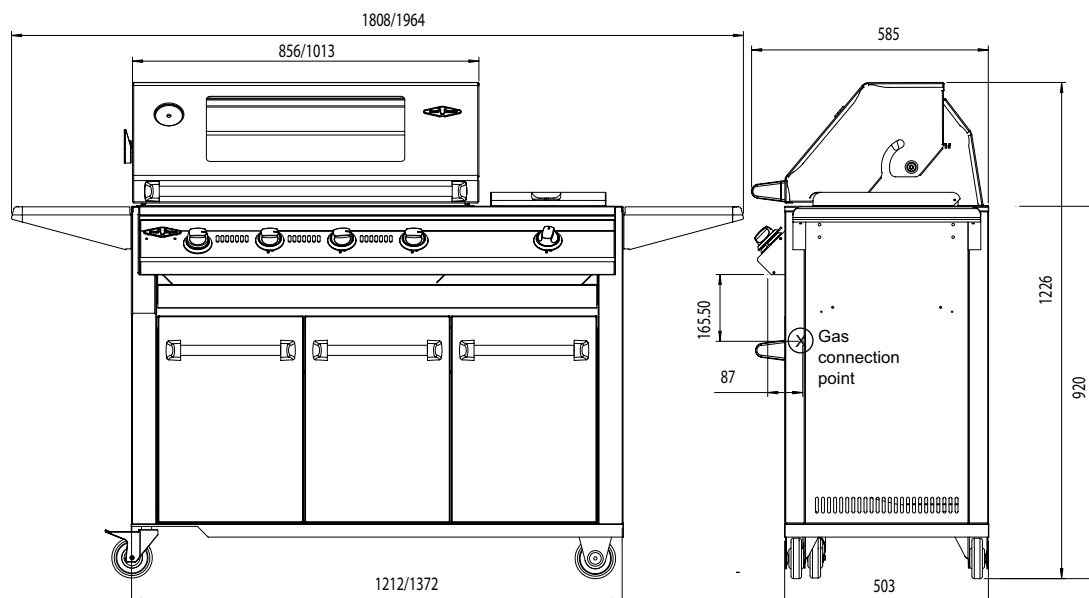



Warranty

BeefEater Barbecues Warranty Terms

Barbecue

Barbecue Frame	Lifetime
Stainless Steel burners	Lifetime
Valves	5 Years
'Quartz Start' Ignition System	2 Years
Vaporizer Grids and Reflectors	2 Years
All Other Parts	2 Years

Cooktops / Cooking Surfaces

Stainless Steel Grills	Lifetime
------------------------	----------

Roasting Hoods

Body	Lifetime
All other parts	1 Year

Side Burners

Side Burner Frame	Lifetime
Burner	5 Years
Cast Alloy parts	5 Years
All other parts	2 Years

Trolleys

Stainless steel parts	Lifetime
All other parts	1 Year

SERVICE ASSISTANCE

To assist you when contacting your after sales service contact to arrange a service call please complete the following details and have them ready when you call.

Model number
Serial number
Retailer purchased from
Date of purchase
Gas type <input type="checkbox"/> LPG/Propane <input type="checkbox"/> NG

BeefEater Sales International
 3-5 Birmingham Avenue
 (PO Box 450)
 Chester Hill NSW 2162
 Phone: +61 2 9755 7912
 Facsimile: +61 2 9755 7913
 E-mail: mail@beefeaterbbq.com
 Website: www.beefeaterbbq.com
 USA Toll Free 1 866 550 2333



Warranty

Beefeater Barbecues Warranty Conditions

Should any part fail due to defective workmanship or faulty materials within the specified period from the date of purchase, BeefEater or its distributor will repair or, (at distributors option), replace the defective part free of charge.

- **LP / Propane Gas Cylinder**

The cylinder manufacturer is responsible for the materials, workmanship and performance of the gas cylinder. Contact your dealer or the cylinder manufacturer in respect of all warranty claims or service.

- **Warranty Administration**

In Australia, warranty is administered by BeefEater Barbecues. In other countries, contact your authorised BeefEater retailer for details of your BeefEater distributor.

- To ensure speedy processing of your warranty service claim, ensure that you record all specific details about your appliance in the space provided. Keep this information handy for future reference.

Not Covered

Exposure of the barbecue appliance to the elements should be minimised. Once the unit has cooled and is cleaned, store the barbecue under cover. Polyester/Vinyl barbecue covers are an optional accessory that will ensure years of trouble free operation.

This warranty does not cover the purchaser or any other person for damage, malfunction or loss due to the following:

- Lack of maintenance, abuse, neglect, misuse, accident or improper installation of this appliance.
- Scratches, dents, corrosion or discolouring caused by heat, abrasive or chemical cleaners or chipping on porcelain parts.
- Corrosion or damage caused by exposure to the elements, grease fires, insects, weather or hail.

Note: Barbecues must be covered when not in use.

- Cleaning and normal wear and tear. Service calls of this nature are chargeable.
- Rusting of cast iron plates, grills and burners.

Note: Rust should be removed by a scrub pad and the surface coated with cooking oil. See owners manual – Caring for cast iron cooking surfaces. Cooktops must be covered when not in use.

- Commercial use of the barbecue.
- Unauthorised repairs during the warranty period
- Removal or re-installation costs.
- Cracks and weathering of timber parts caused by exposure to the elements or damage by weather, heat, insects, chemicals or foods acids or juices.

Conditions of Warranty

1. The appliance is delivered to the BeefEater distributor's service department or authorised service agent and freight charges both ways are paid by the owner. No liability is accepted for loss or damage during transit.
2. The appliance is installed by a qualified person and operated and maintained in accordance with the instructions supplied. Repairs or service must be carried out by an authorised person.
3. Installation must conform to the applicable Gas, Electrical and Building standards laid down by the local codes for your country or region.
4. No alterations or repairs have been carried out without obtaining the distributors prior consent. Such repair or any replacement does not extend the warranty period.
5. Proof of purchase together with the warranty card must be provided to verify purchase date and establish the warranty period. Only the original purchaser is covered under this warranty.
6. The warranty period is calculated from the date of purchase only.
7. Where this warranty is inconsistent with any state laws, the statutory rights of the purchaser shall prevail.
8. Parts installed from other manufacturers' products will void this warranty.



Accessories Available

Your retailer can advise on the range of BeefEater accessories available to help you take full advantage of the barbecue cooking opportunities available with your roasting hood.



Mitt Set - handle baking dishes and other hot items safely and with confidence



Poly Cover - protect your investment from the weather. Designed to fit Beefeater barbecues



Meat Thermometer - takes the guess work out of cooking by telling you when your food is cooked



Chef Set - all you need to look like a pro



Baking Dish - for casseroles and other foods that need to be confined or contained



Motorised Rotisserie - cooks evenly without being too close to direct heat

BeefEater Sales International

P.O. Box 450, Chester Hill, NSW, Australia 2162

PH: +61 2 9755 7912 FAX: +61 2 9755 7913

E-mail: mail@beefeaterbbq.com Website: www.beefeaterbbq.com

Australia's Leading Barbecue