

Finally the "Perfect Air Purifier"

HEPA and GRANULAR CARBON
(up to 180 lbs.)

Now Indoor Air

Will NOT

Make You Sick

Our Famous Guarantee

- MORE FEATURES
- MORE FILTRATION
- MORE OPTIONS
- MORE MODELS
- LESS COSTLY

HIGHLY EFFECTIVE FOR USE IN

- Portables
- Mobile homes
- Entire homes
- Offices
- Bedrooms
- Child care centers
- Dental offices
- Retirement homes
- Hotel/Motel
- Restaurants
- Smoking Rooms
- Print Shops
- Beauty Salons
- Photo Lab's
- Soldering Shops
- Auto Shops
- Computers
- Photocopiers
- Laser Printers
- Clean Rooms
- Industries
- Warehouses
- Plus many other applications



WHEN PURE AIR COUNTS; COUNT ON Aller Air™!

Serious Purification Systems (Over 80 Models Available)

Air flow from 50 to 5000 CFM

For:

- Laboratories
- Jeweller Soldering

200 CFM

REVERSE LAMINAR FLOW

For:

- Allergies
- Asthma
- Respiratory Problems
- Smoking

4000 SERIES

400 CFM

HOME

For:

- Sick Building Syndrome
- Chemicals
- Odors
- Gases

18000 SERIES

400 CFM

INDUSTRIAL

For:

- Desk Top
- Nursery
- Travel
- Truck Cab

50 CFM

PORTABLE

AVAILABLE

- Carbon filters without silicone
- Refillable carbon filters
- Units for multiple chemical sensitivities

For:

- Isolation
- Day Care
- Medical Recp.

For:

- Fire Restoration
- Sewer Backup

2049 Le Chatelier
Laval, Quebec, Canada
H7L 5B3

Tél.: (450) 688-4278
1-888-852-8247

Fax: (450) 688-3939

I-6500 SERIES OPERATIONS and MAINTENANCE MANUAL

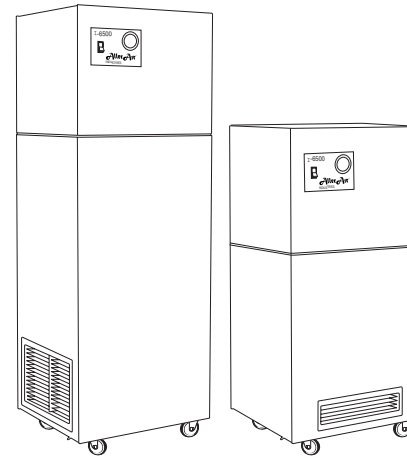

I-6500 A

I-6500 B/C/D

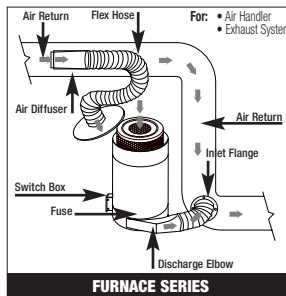

FURNACE SERIES

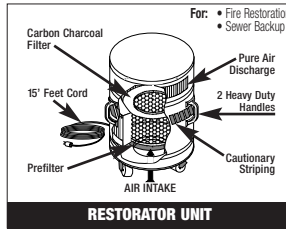

RESTORATOR UNIT

1.0 Introduction	1
2.0 Safety Precautions	1
3.0 Principle of Operation	1
4.0 System Components	2
4.1 Unit Specifications	2
5.0 Unit Receiving Instructions	3
5.1 Unit Inspection	3
5.2 Pre Start-up Checklist	3
6.0 Start-Up	3
7.0 Equipment Maintenance Procedures	4
7.1 General Filter Maintenance	4
7.2 Particulate Filter Replacement	4
7.3 Chemical Filter Tray Maintenance	5
7.4 CFT Assembly Maintenance	5
7.5 Blower Maintenance	5
7.6 Annual General Inspection	6
8.0 Operation	6
8.1 Controls	6
8.2 Positioning of Unit	6
8.3 I-6500 Filter Combinations	7
9.0 Warranty	8
9.1 Toxic gas adsorbent purifier	8
10.0 Spare Parts, Drawings and Schematics	8-9-10
Spare Parts	8
Control Panel Layout	9
Terminal Strip Connections	9
Filter Holding Module, and its installation	9-10
Room Airflow Patterns	10
General Equipment Layout	10
Troubleshooting Guide	10

IMPORTANT NOTICE:
This unit is not designed for use in a flammable application.

1.0 Introduction

You are now the owner of an **I-6500 SERIES** unit, an advanced effective indoor air purifier. You may now expect a noticeable improvement in your air quality as your **I-6500 SERIES** begins the process of reducing microscopic airborne particulate as well as harmful chemical gases, smoke, dust and pollen.

2.0 Safety Precautions

- Carefully read all the instructions contained in this manual before operating the unit.
- Keep this manual as it contains information for proper operations and maintenance.
- Keep all fastening hardware tight to ensure that the unit is in safe working condition.
- Familiarize yourself with the way in which filters are removed, installed, and serviced.
- **CAUTION:** All filters must be in place whenever this machine is in operation and doors closed. Operating it with one or more filters missing, the door open, and/or inferior filters in place will cause amperage to increase and the motor to overload. Permanent damage could result.
- Use only on a grounded electrical circuit; do not use a two-wire electrical prong adapter to defeat the three-pronged plug on the end of the cord. Unit must be grounded
- When servicing the motor, be careful when touching the exterior of the motor as soon as it has been turned off; it may be hot enough to be painful or cause injury. With modern motors, this condition is normal when operated at rated load and voltage, as they are built to operate at higher temperatures.
- **Do not substitute any other filters (particulate or chemical) for those supplied as this will alter the design characteristics.**
- **DO NOT SERVICE MOTOR OR CONTROL PANEL UNLESS UNIT IS UNPLUGGED FROM RECEPTACLE (ITS POWER SUPPLY)!**

3.0 Principle of Operation

- The **I-6500** features a threefold method of operation;
 - A) Captures general particulate.
 - B) HEPA filter removes microscopic particulate matter.
 - C) Chemically adsorbs, reacts or scrubs toxic or nuisance gases.
- This unit is supplied with an eight-foot extension cord and 360 degree swivel casters.
- FILTER SEQUENCE HAS BEEN SPECIALLY SELECTED FOR YOUR APPLICATION.

ROOM AIRFLOW PATTERNS

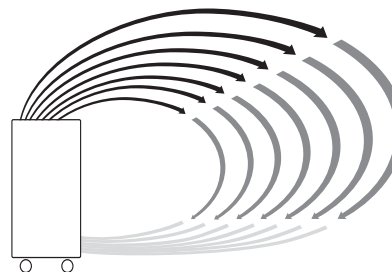

FILTER HOLDING MODULE

- (1) or (2) Filter Holding Modules.
- Slide into unit as per drawing.
- Please ensure airflow direction arrows on label are pointing up.

NOTE:

Attach panel covers on filter canister before inserting into unit

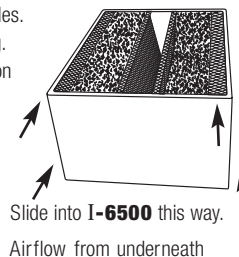

GENERAL EQUIPMENT LAYOUT

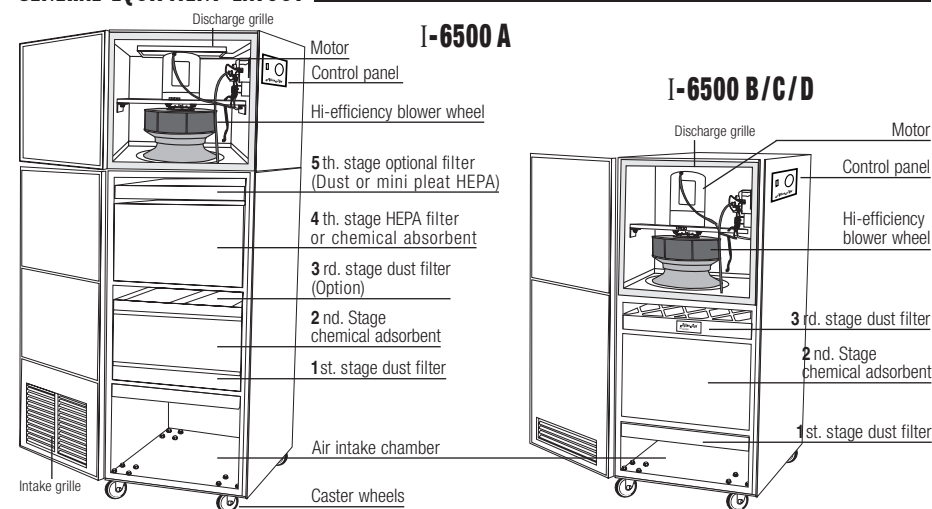

TROUBLESHOOTING GUIDE

Symptoms:	Possible Cause:	Suggested Solution:
Unit will not start	<ul style="list-style-type: none"> • Faulty Power Supply • Return or supply grille blocked • HEPA filter improperly installed • Blown fuse • Unit not plugged into receptacle 	<ul style="list-style-type: none"> • Check breaker box • Remove obstruction • See Section 7.2 • Replace fuse • Plug unit in
Excessive noise	<ul style="list-style-type: none"> • Blower wheel contacting cone • Fan isolators loose or off 	<ul style="list-style-type: none"> • Realign / Replace wheel • Replace isolator
Insufficient airflow	<ul style="list-style-type: none"> • Obstruction in system • Clogged filters 	<ul style="list-style-type: none"> • Remove obstruction • Replace filters
Excessive airflow	<ul style="list-style-type: none"> • Filters not in place 	<ul style="list-style-type: none"> • Install filters

CONTROL PANEL LAYOUT I-6500 SERIES

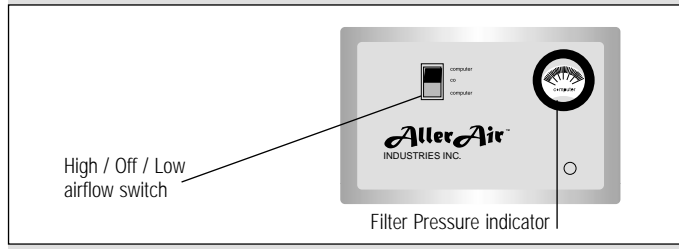

TERMINAL STRIP CONNECTIONS

(ON CONTROL PANEL IN I-6500)

CONTROL PANEL SIDE	1	• 120v Main Power Supply, black
	2	• 120v Main Power Supply, green
	3	• 120v Main Power Supply, white
	4	• empty
	5	• empty
	6	• empty
	7	• Motor low, red
	8	• Motor high, black
	9	• Motor neutral, white
	10	• Motor ground, green

FILTER HOLDING MODULE

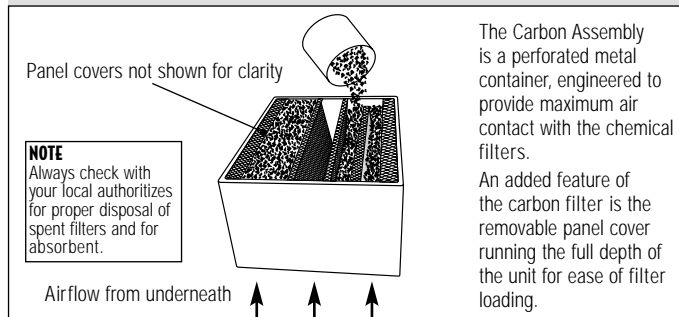

4.0 System Components

CABINET

Attractive appliance finish, designed to blend in with any decor. The I-6500 system is mounted on recessed casters for ease of portability.

FILTERS

- Ashrae-rated dust filters.
- DOP-rated high efficiency HEPA filters.
- Specially selected particulate and chemical filtration based on local chemical pollutants.

BLOWER ASSEMBLY

The blower is factory balanced and tested to ensure quiet and vibration-free operation. The blower in the I-6500 features a motor mounting system designed to reduce vibration.

CONTROL PANEL

Recessed control panel is designed for easy monitoring. Features include two position on/off switch and visual pressure indicator.

GRILLES

Strategically located intake and discharge grilles will ensure proper air current and air patterns in the selected environment.

PLUG

Eight-foot grounded extension cord for easy placement.

4.1 UNIT SPECIFICATIONS

Model	I-6500 A	I-6500 B-C-D
Air Flow:	1000 CFM (nominal)	1000/700/500 CFM
Dust Filters:	# 65HF0412, (2) only	# 65HF0412
Mini Pleat 60%:	# 65FH0413, (1) only	# 65FH0413
HEPA Filter:	# 65HF0411 (1) only	# 65HF0411
Chemical Filter Assembly:	# 65FCC311 (1) or (2), EXEC	# 65FCC311 (1)
Anti Microbial:	# 65FH0414 (1) only	# 65FH0414 (1)
Dimensions:	Height: 70" Width: 21" Length: 24 1/2"	48" 21" 24 1/2"
Voltage:	120/1/60	120/1/60
Maximum Power Consumption:	390 watts	390 watts
Maximum Current:	5.4 amps	5.4 amps
Approximate Weight	250 to 340 lbs.	175 to 250 lbs.

(Depending on the filter configurations).

5.0 Unit Receiving Instructions

5.1 UNIT INSPECTION

Upon receipt, inspect unit for either visible or concealed damage. Damage should be immediately reported to the transport company.

The **I-6500 B-C-D** units are delivered to you in the following combinations:

- **I-6500 B**
1000 CFM - 80 lb. carbon filter - Anti-microbial pre-filter.
Optional feature: 2" x 24" x 12" HEPA filter or 20" x 24" x 12" HEPA filter, 2" carbon filter.

- **I-6500 C**
750 CFM - 80 lb. carbon filter - Anti-microbial pre-filter.
Optional feature: 2" x 24" x 12" HEPA filter or 20" x 24" x 12" HEPA filter, 2" carbon filter.

- **I-6500 D**
500 CFM - 80 lb. carbon filter - Anti-microbial pre-filter.
Optional feature: 2" x 24" x 12" HEPA filter or 20" x 24" x 12" HEPA filter, 2" carbon filter.

Optional feature
Specialized absorbents
(ask for cost)

UV bulb
(ask for cost)

The **I-6500 A** unit is delivered to you in one of three ways:

- **PARTICULATE APPLICATION:**
Unit contains four particulate filters mounted within the unit.
1 - Dust filter, 1-60% Mini pleat, 1-HEPA 99.97% down to 0.3, and 1-Anti-microbial filter.
- **HEAVY DUTY ODOR APPLICATION:**
Unit contains two particulate filters mounted in the unit. The one or two chemical absorbent assemblies are shipped loose in two cardboard boxes on top of the unit.
- **NORMAL DUST and ODOR APPLICATION:**
Unit contains a HEPA particulate filter and one odor filter in a cardboard box on top of the unit. Two dust pre & post filters.

5.2 PRE START-UP CHECKLIST

NOTE: Carbon canister is sent in a separate box and must be installed.

- Open lower door insert the carbon filter canister (1) or (2) with the rubber gasket down.
- Labels and serial numbers are present for future identification.
- Verify that the power supply is compatible with the equipment (120-volt /15 amps /1 phase /60hz).
Also check that the unit is plugged into a grounded receptacle.
- Ensure that unit-mounted casters are tight and secure before manoeuvring the system.

6.0 Start-Up

- Place unit on a flat surface, ensure all filters are installed (see **Equipment Installation and filter Maintenance Guide** on face of unit).
- Ensure that supply and return air grilles are not obstructed in any way (air circulation patterns will be inhibited if airflow is obstructed).
- Insert male end of cord into 15-amp circuit. Unit should be connected to an independent 15 amp circuit.
- Turn power toggle Switch to "HIGH" position and to verify that system is operating properly. Do the same in "LOW" position.
- Pressure gauge should read between 0.5 and 1.1 with filters in place.

WARNING: DO NOT OPERATE THE UNIT UNLESS ALL FILTERS ARE IN PLACE.

9.0 Warranty

AllerAir Industries warrants its equipment to be free from defect in material and workmanship under normal use and service for a period of one year from date of shipment. AllerAir's obligation under this warranty shall be limited to replacing any parts, thereof, which shall be demonstrated to have been defective. This is expressly in lieu of all other warranties, express or implied, including the warranties of merchantability and fitness.

AllerAir claims no warranty as to merchantability or as to the fitness of the merchandise for any particular use and shall not be liable for any loss or damage. No person, firm or corporation is authorized to assume for AllerAir any other liability in connection with the sale of these goods. Equipment, parts and material manufactured by others and incorporated in AllerAir's equipment are warranted by AllerAir only to the extent of the original manufacturer's liability to AllerAir Industries Inc. Expendables are not warranted for any period of time.

Conditions and Limitations:

This warranty does not cover abuse, misuse, maintenance negligence, improper assembly, acts of vandalism, acts of God, fear wear, modifications of the equipment or installation of a part not recommended by AllerAir Industries Inc., as well as operation of the equipment at voltages other than those specified by AllerAir Industries Inc.

9.1 TOXIC GAS ADSORBENT PURIFIER

ALLERAIR MODEL I-6500 room air purifier is designed to scrub the toxic exhaust gas in a 2000 to 3500 cubic foot room. The **ALLERAIR MODEL I-6500** room air purifier is provided with installation and operation instructions. The **ALLERAIR MODEL I-6500** room air purifier includes replaceable filter elements with an activated charcoal bed for chemical gas and odor removal; a centrifugal blower is housed in a sandstone or white gas tight cabinet enclosure.

10.0 Spare Parts, Drawings and Schematics

Qty:	Description:
1	Control Panel Assembly
1	Pressure Gauge
1	Toggle Switch
1	Fuse
1	Blower/Motor Assembly
4	Fan Isolators
2	Dust Filters
1	Mini Pleat
1	HEPA Filter
1/2	CFT Housing
1/2	Intake Grille
1	Discharge Grille
4	Castors
1	3/16" Gasket Roll

8.3 I-6500 FILTER COMBINATIONS

Economical particulate solution

I-6500 D
500 CFM

Standard Equipment

- Anti-microbial pre-filters
- 80 lb. carbon filter

Optional Feature

- 2" x 24" x 12" HEPA filter (\$129.98 extra)

Or

- 20" x 24" x 12" HEPA filter
- 1/2" carbon filter

Economical particulate solution

I-6500 C
750 CFM

Standard Equipment

- Anti-microbial pre-filter
- 80 lb. carbon filter

Optional Feature

- 2" x 24" x 12" HEPA filter (\$129.98 extra)

Or

- 20" x 24" x 12" HEPA filter
- 1/2" carbon filter

Heavy duty chemical odor or particulate solution

I-6500 B
1000 CFM

Standard Equipment

- Anti-microbial pre-filter
- 80 lb. carbon filter

Optional Feature

- 2" x 24" x 12" HEPA filter (\$129.98 extra)

Or

- 20" x 24" x 12" HEPA filter
- 1/2" carbon filter

Heavy duty dust and chemical odor solution

I-6500 A
1000 CFM

Standard Equipment

- 2 Anti-microbial pre-filters
- 20" x 24" x 12" HEPA filter
- 80 lb. carbon filter

Or

- 20" x 24" x 2" HEPA filter
- 16.0 lbs. of carbon

Specialized absorbents available (ask for cost)

I-6500 B / I-6500 C / I-6500 D

Model	I-6500 B-C-D
Dimensions	Height: 48" Width: 21" Length: 24 1/2"
Weight	1207 lbs
Maximum Power Consumption	300 watts
Maximum Output	5.4 cfm
Approximate Weight	115.5 x 26.0 lbs

Dimensions are in feet and inches.

I-6500 A

Model	I-6500 A
Dimensions	Height: 70" Width: 21" Length: 24 1/2"
Weight	1207 lbs
Maximum Power Consumption	300 watts
Maximum Output	5.4 cfm
Approximate Weight	250.5 x 30.0 lbs

Dimensions are in feet and inches.

NOTE: Carbon filter lid not in place for visual appearance. (You must attach lid to filter canister)

7.0 Equipment Maintenance Procedures

Proper maintenance is critical to extend the life of the filtration system. The information presented below outlines basic maintenance procedures to ensure the **I-6500** units will provide trouble-free operation for years to come. The **I-6500** is designed to allow quick access to the particulate filters, chemical filters, blower/motor and control panel assemblies.

7.1 GENERAL FILTER MAINTENANCE

It is very difficult to predetermine a specific maintenance schedule as the rate of dust loading and chemical filter consumption will vary for each application. Periodic inspection of the filters and pressure gauge during the first few months of operation should help establish an appropriate replacement schedule.

AllerAir Industries, through its years of experience has established the following recommendations for a "typical" replacement filter schedule:

IT IS VERY IMPORTANT TO CHANGE FILTERS ON A REGULAR BASIS.

Filter Type	Part No.:	Qty.:	Suggested Replacement
Dust Filters		1	Every two-three months
Mini Pleat 60% HEPA		1	Every six months
Chemical Filters		1 or 2	Every six to twelve months
HEPA Filter		1	Every twelve months
Anti-microbial		1	Every two-three months

NOTE: These recommendations are for average room conditions.

7.2 PARTICULATE FILTER REPLACEMENT

- Open with appropriate tool to avoid stripping of screws.
- Carefully slide out filters along their support channels (see diagram in back of manual).
- Slide clean filters gently into place.
- Ensure Dust Filters are replaced with mesh screening on the upper side.
- If encountering difficulties, confirm that there are no obstructions in the filter track.
- Mini pleat 60% HEPA filters must be replaced as per airflow arrow on the filter casing.
- HEPA filters should be replaced if the filter gauge on the control panel exceeds 1.5 - 1.6".
- Large HEPA filters will be installed with gaskets facing down on the filter track.
- Outmost care must be taken not to damage the exposed portions of the HEPA filter.

7.3 CHEMICAL FILTER TRAY MAINTENANCE

Heavy Duty Odor Applications

It is essential that the chemical filters be replaced approximately once every twelve months OR immediately following any detection of odor on the discharge of the system.

After an operating period of twelve months (or when the filters are consumed), call your authorized distributor to purchase a new set of chemical filtration assemblies prior to removal of existing filter / or replacement odor absorbant.

To replace CFT Filtration Assemblies (Part No.: 65FC0500):

- Ensure that the unit is unplugged.
- Open door with appropriate tool to avoid stripping of screws.
- Slide out existing Carbon Filtration Assemblies from the unit. (See diagram at bottom of last page).
- Remove newly purchased Filtration Assemblies from the box shipped in.
- Vacuum exterior of new Filtration Assemblies with a bristle attachment to remove excess dust and to prolong the life of the dust and HEPA filters.
- Reinsert new Filtration Assembly back into the system (ensure airflow arrows are pointing up, see diagram on last page of this manual).
- Return door to the closed position and verify that an airtight seal is maintained.
- Place consumed Filtration Assembly directly into reusable cardboard box. NOTE: it is advised to replace dust filters after replacing Carbon filter.

To refill existing Carbon filter cell with new odor absorbent:

- Slide out existing Carbon filters (see diagram on last page of manual).
- Unscrew the two (2) top panel covers and lift off cover.
- Pour out used odor absorbent (**This procedure may be dusty, therefore a dust mask is recommended**).
- Refill Carbon containers with fresh odor absorbent.
- Replace the 2 panel covers and re-insert into unit as per diagram on last page of manual. NOTE: It is advised to replace dust filters upon replacing the Carbon filter.

7.4 CFT ASSEMBLY MAINTENANCE

Light Duty Odor Applications

Filters used in Light Duty Odor Applications are very simple to maintain. When it is time to replace filters, remove used Filters Assembly from the unit and discard. Replace with new Filters Assembly by sliding filter into proper slot.

7.5 BLOWER MAINTENANCE

WARNING: SWITCH UNIT OFF AND UNPLUG POWER CORD FROM WALL BEFORE SERVICING THE BLOWER.

The motor is equipped with electric motor grade double shielded ball bearings and a special lubricant, assuring long life and quiet operation. No extra motor maintenance required.

7.6 ANNUAL GENERAL INSPECTION

- The sealing integrity of the **I-6500** is essential. Every 12 months, verify that all gaskets are in proper condition. Should the door gaskets adhere slightly to the unit when opening a door, lubricate its surface with a transparent grease or petroleum jelly.
- Should the unit be relocated continuously for optimum efficiency, ensure casters are tightly fastened.

8.0 Operation

The air is drawn into the unit through an intake grille located in the lower door or side inlets on the B-C-D series. The air then passes through the various stages of particulate and odor/gas filtration. Powered by a 120-volt motor/blower assembly, the clean air is then released through the top discharge grille into the controlled space.

8.1 CONTROLS

For your convenience, the **I-6500 SERIES** is equipped with a pressure gauge recessed within the control panel to allow for a visual indication of filter pressure. **IN THE EVENT OF HIGH FILTER PRESSURE (1.5" TO 1.6" wc), CALL YOUR AUTHORIZED DISTRIBUTOR IMMEDIATELY TO REPLACE YOUR FILTERS.**

In case control panel servicing is required, an electrical schematic is located in this manual

8.2 POSITIONING OF UNIT

Portability was taken into consideration when designing the System. Mounted on four casters, the unit can be wheeled virtually anywhere in the room for optimal convenience. The unit is designed in an up-flow configuration allowing the air to create a "sweeping" effect across the room (see **Airflow Patterns Drawing** at the back), moving across the room in a downward motion. The clean air pushes particulate and gaseous matter towards the floor level and draws it into the intake grille located on the lower door. This configuration allows the particulate which have already accumulated on the ground to be pulled towards the return air grille. This results in a very effective means of cleaning the space.

The **I-6500 SERIES** is more efficient as it is placed closer to its intended source. Conversely, the unit's efficiency is diminished the further it is placed from the source of pollutants. The unit can be conveniently positioned against a wall. The back of the unit must be placed at least 2" away from the wall such that the power cord remains free flowing. It has been designed so that all servicing is accessed through the front of the unit. The **I-6500 SERIES** has been uniquely designed for a throw of up to forty feet.