



BioGP™ *Air Purifier* User's Guide

www.RabbitAir.com

Model No. SPA-421A and SPA-582A



Safety Instructions

WARNING: When using electrical appliances, basic precautions should always be followed to reduce the risk of fire, electric shock, and injury to persons, including the following:

- Read all instructions before using the BioGP™ air purifier.
- Use only as directed by the BioGP™ air purifier user's guide. To reduce the risk of electric shock, do not attempt to service the product in any way other than in the manner described in this user's guide.
- Please observe extreme caution when the BioGP™ air purifier is used by or near children.
- The BioGP™ air purifier is for indoor use only.
- BioGP™ air purifier operates at 120V AC and 60Hz only.
- The BioGP™ air purifier is not intended for use in bathrooms, laundry areas and other damp indoor environments. Keep the BioGP™ air purifier away from water at all times. Never place the unit anywhere near bathtubs or sinks.
- Do not use the BioGP™ air purifier near fireplaces or in areas where flammable or combustible products or vapors may be present.
- Turn off the BioGP™ air purifier before unplugging it from power outlet.
- Always unplug the BioGP™ air purifier from power outlet when not in use and before servicing or cleaning the unit.
- To reduce the risk of electric shock, the BioGP™ air purifier has a polarized plug. This plug will fit in a polarized outlet only one way. If the plug does not fit into the outlet, reverse the plug. If it still does not fit, contact qualified personnel to install the proper outlet. Do not alter the plug in any way.
- To reduce the risk of electric shock, do not touch the BioGP™ air purifier or its power plug with wet hands.
- Always keep the BioGP™ air purifier cord away from heated surfaces.
- Do not operate BioGP™ air purifier if the plug or cord appears damaged or is damaged. Return the unit to authorized service facility for examination and repair.
- Any attempts to open or repair the BioGP™ air purifier without written permission from Rabbit Air will void the warranty and could cause serious personal injury to the user and/or result in severe damage to the unit.
- Do not use the power cord to lift, pull, carry or drag the BioGP™ air purifier, Avoid pulling the power cord against or around sharp corners or edges.
- Do not unplug the BioGP™ air purifier by pulling its power cord. Remove the power plug from its outlet by grasping the plug itself and pulling gently.
- When the BioGP™ air purifier plugs into the power outlet, do not put any object into the openings of the unit. Also keep all fingers, body parts, hair, jewelry and loose clothing away from the openings.

Cautions Concerning the Operation of BioGP™ Air Purifier

- Do not block the intake and air outlet.
- Do not use the unit near or on hot objects such as a stove.
- Do not use the unit where it may come into contact with steam.
- Do not use the unit on its side.
- Do not install the unit in a location where there is heavy generation of oily residue such as kitchen.
- Do not use detergent or soap to clean the unit.
- Do not operate the unit without installing the filters.
- Do not wash & reuse the BioGP™ HEPA filter.
- When transporting the unit, always hold the handle on the back of the unit.

Remote Control Limitations

- Do not use the remote control near inverter lighting equipment or electronic light fixtures.
- Avoid leaving the remote control in direct sunlight. Heat may interfere with remote control signals.

Installation Guidelines

- Keep a distance of at least 3 feet of space between air purifier and any equipment which involve electric wave such as televisions, radios or wave clocks.
- Leave at least 2 inches of space between the wall and the BioGP™ air purifier.
- Avoid locations where BioGP™ air quality sensors are exposed to direct wind.
- Avoid locations where excessive dirt comes into contact with the intake or air outlet.

Part Names

● Front View of Air Purifier

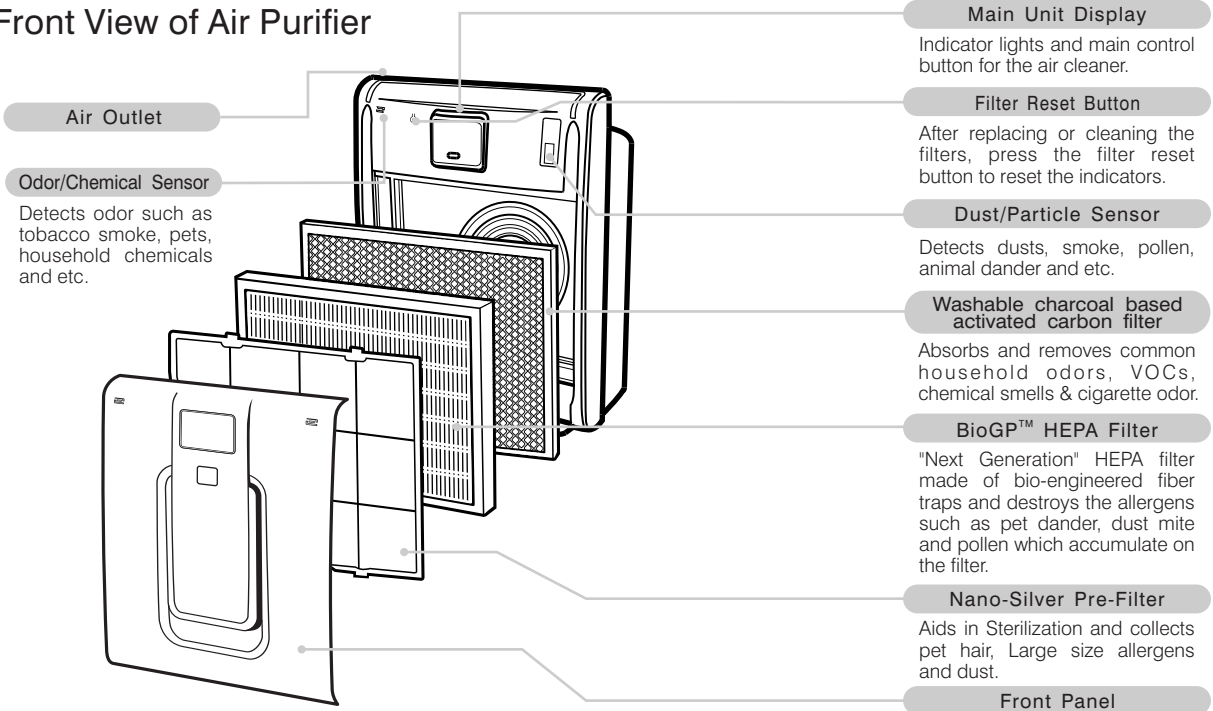

● Back View of Air Purifier

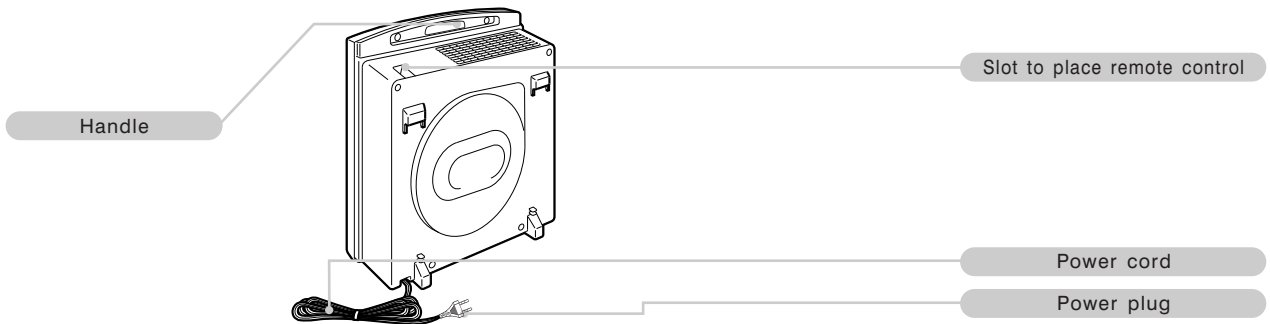

● Main Unit Display

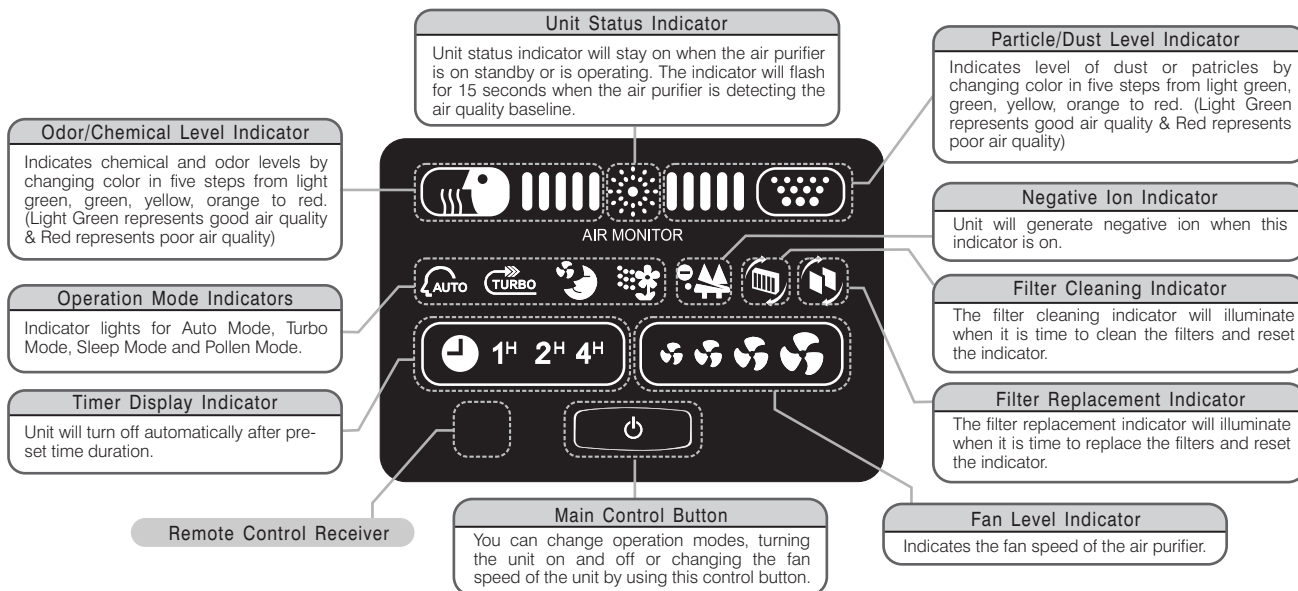

● Remote Control Operation

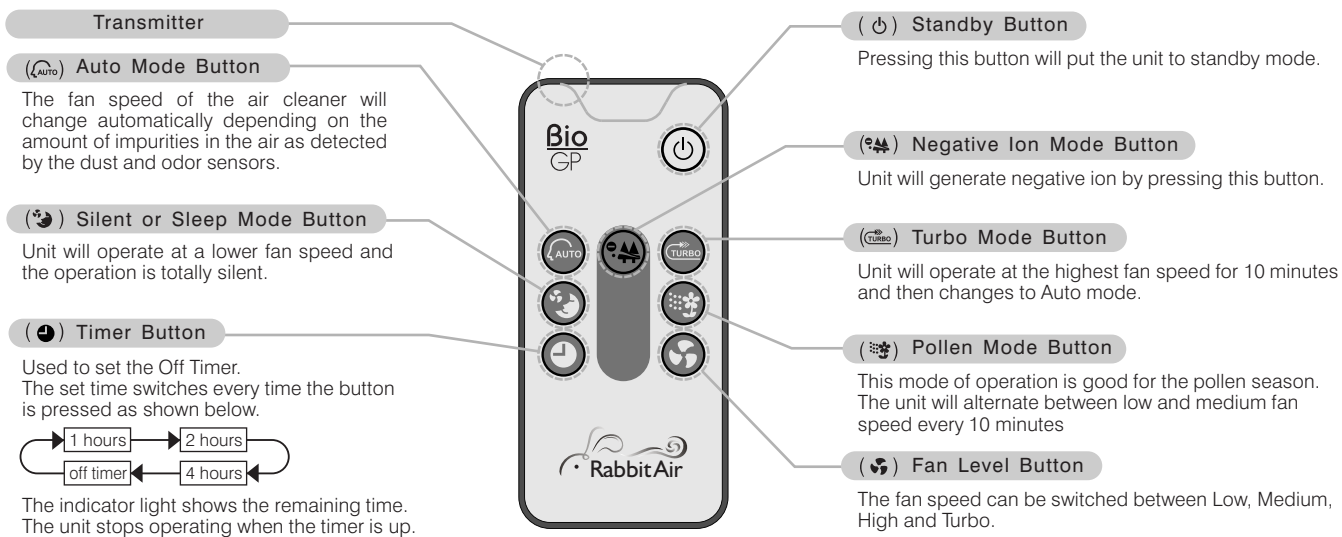

Preparation

* List of Parts

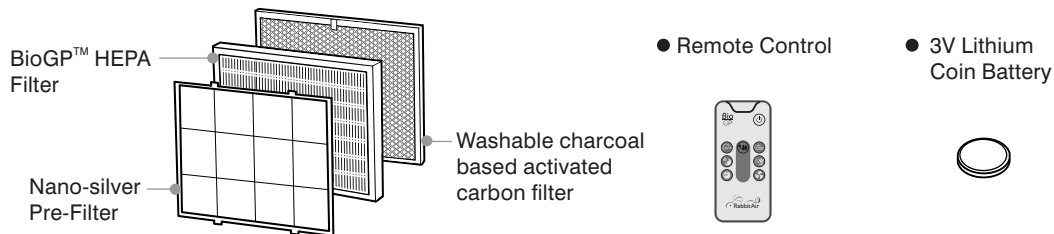

1. Filter Installation

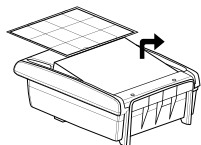

CAUTION To maintain the quality of the filters, they are placed in the unit within plastic bags. Please remove the filters from the plastic bags before using the unit.

Step 1 Place the unit facing up and Remove the front panel

- ① Lay the unit on a flat surface such as table or floor. Make sure not to pinch the power cord on the rear of the unit.
- ② Put your hands at the bottom of the front panel and lift the panel up gently.

Step 2 Remove Plastic bags from the BioGP™ HEPA filter and Washable charcoal based activated carbon filter.

- ① Remove the pre-filter from the unit.
- ② Remove Plastic bags from the BioGP™ HEPA filter and Washable charcoal based activated carbon filter.
- ③ First, install the Washable charcoal based activated carbon filter. The filter handle should be facing the front panel.
- ④ Install the BioGP™ HEPA filter with the word "Front" on the filter frame face toward you.

Step 3 Re-insert the pre-filter and the front panel.

- ① First, install the pre-filter. The filter handles should be facing the front panel.
- ② Re-insert the front panel back to the unit. Press in the hooks on the bottom of the front panel into the unit. You should hear a "click" sound if installed properly.

Inserting Battery in the Remote Control.

- ① Flip over the remote control. Press and slide out the battery holder
- ② Insert battery with positive side facing up.
- ③ Close the battery holder.

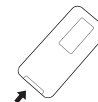
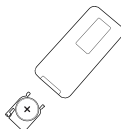
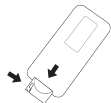

Battery Information

- The batteries for this remote control are for initial use only. Change the batteries when necessary.
- Incorrect usage of the batteries may cause battery fluid leakage and/or damage.
- When replacing battery, replace battery with new one of the same type (Use 3V Lithium Coin Battery).
- When not using the unit or remote control for an extended period, remove the batteries. (This prevents malfunction of the remote control from battery fluid leakage.)
- The batteries are for initial use only and may be depleted within 1 year.



How to set up Home Air Quality Baseline.







- When the power plug is inserted into the wall outlet, the unit will register the current home air quality as a baseline (reference point).
- It will take 15 seconds for the Air Quality Level Sensors to indicate the air quality level. You will see the unit status indicator on the main unit display flashing for 15 seconds.
- The Air Quality Level Indicator displays a color-coded indicator light depending on relative changes to the environment from the time the power plug is inserted into the wall outlet and thereafter.
- The Air Quality Level Indicator can be turned off using the Standby button on the remote control.

Important

When the air is heavily polluted at the time the power plug is inserted, the unit may not work properly in auto mode because the baseline or reference point is too high. To reset the air quality baseline, unplug the unit and re-insert it when the air quality is in normal condition.

Operation

- Unit can operate by using either:
 1. Remote Control
 2. Main Unit Control Button. (Some features will not be available by using just the unit control button.)
- The remote control or main unit control button can activate the following modes.
 - ① Automatic mode ()
 - ② Silent mode ()
 - ③ Manual mode ()

Start operation.	Remote	Main	
① Auto mode ()	○	○	Unit automatically select fan speed based on air quality.
② Turbo mode ()	○	×	Unit operates at turbo speed for 10 minutes and then returns to auto mode.
③ Silent mode ()	○	○	Unit operates at the lowest and the quietest fan speed.
④ Manual mode ()	○	○	Unit operates at the pre-set fan speed.
⑤ Pollen mode ()	○	×	The unit will alternate between low and medium fan speed every 10 minutes.
⑥ Timer mode ()	○	×	Unit operates for a pre-determined time, then shuts off.
⑦ Negative Ion mode ()	○	×	Turns negative ion generator on/off.

Remote control operation

- Activate remote control by pressing the any button. Be inline with the front side of the unit. (The maximum range of effectiveness is 23 feet)
- Avoid exposure to direct sunlight; inverter lamp and high frequency equipment. It might affect performance of remote control.
- If air purifier responds properly, a short beep will sound and operation will start.
- Please try to replace the battery if the remote control does not work properly.

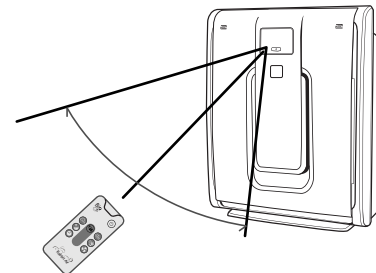

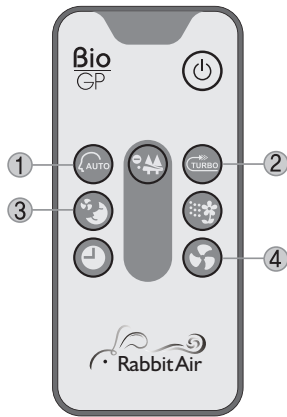









1 Auto Mode ()

The fan speed of the air cleaner will change automatically depending on the amount of impurities in the air as detected by the dust and odor sensors.

- Press the Auto Mode button on the remote control to start the Auto Mode operation.

Strat operation ( : ON) ( : OFF)					
Air Quality Level Indicator					
Fan Speed	Silent	Low	Med	High	Turbo
Mode of Operation					



ATTENTION

- When the air is heavily polluted at the time the power plug is inserted, the unit may not work properly in auto mode because the baseline or reference point is too high. To reset the air quality baseline, unplug the unit and re-insert it when the air quality is in normal condition.
- The unit will operate at silent fan speed when the air quality level is normal or is below the baseline level.

2 Turbo Mode ()

The air purifier operates at turbo fan speed for 10 minutes and then changes to Auto mode.

- Press the Turbo Mode button on the remote control to start the Turbo Mode operation.

Turbo Mode		
Mode of Operation	First 10 Minute	After 10 Minute
		

3 Silent Mode ()

The air purifier operates at silent fan speed continuously.

- Press the Silent Mode button on the remote control to start the Silent Mode operation.

Silent Mode	
Mode of Operation	

4 Manual Mode ()

The air purifier operates at the selected fan speed continuously.

- Press the Fan Level Button on the remote control to start the Manual Mode operation.

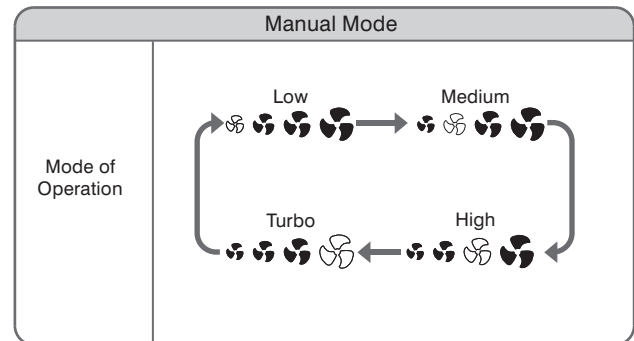

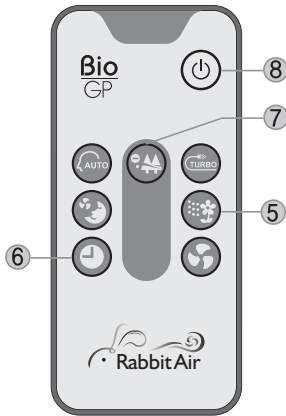

5 Pollen Mode (🌸)

This mode of operation is recommended for the pollen season. The unit will alternate between low and medium fan speed every 10 minutes.

- Press the Pollen Mode button on the remote control to start the Pollen Mode operation.

Pollen Mode	
Mode of Operation	

6 Timer Mode (⏰)

The unit will stop operating when the timer is up.

- Press the Timer Mode button on the remote control to start the Timer Mode operation.

Timer Mode	
Timer settings	<p>Used to set the Off Timer. The set time switches every time the button is pressed as shown below.</p> <p>The indicator light shows the remaining time. The unit stops operating when the timer is up.</p>

7 Negative Ion Mode (⚡)

Unit generates negative ion by pressing Negative Ion Mode button.

Negative Ion Mode	
Mode of Operation	

ATTENTION

The BioGP™ Air Purifier produces millions of healthy "negative ions" to improve the air you breathe and freshen your indoor environment through the use of anion generator inside of the unit discharge. The negative ions help reduce suspended particulate, and at the same time, make it difficult for pollutants to become airborne in the first place. Negative ions are odorless, tasteless, and invisible molecules that we inhale in abundance in certain environments. Think mountains, waterfalls, and beaches. Scientific research shows negative ions may help to alleviate depression, relieve stress, and boost our daytime energy. The Rabbit Air BioGP™ air purifier uses non-ozone clusters to produce negative ions, therefore, our unit has zero ozone emission and it is harmless to human and the environment.

8 Standby (⏻)

Press the Standby button on the remote control to stop the unit.

Main Unit Control Button

- You can control the air purifier by the main unit control button. When you press the button, the operation mode of the air purifier will be changed according to the following diagram.

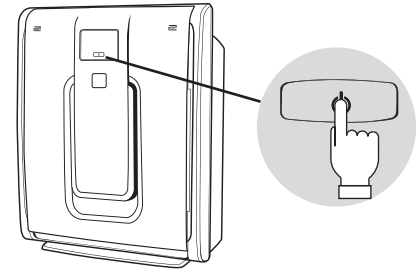
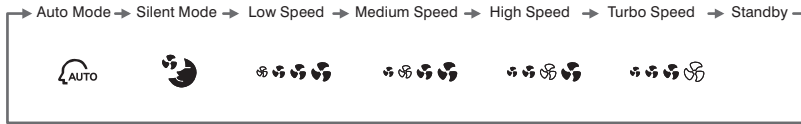

Cleaning and Maintenance

- To maintain optimum performance of this product, please clean the unit and filters as recommended.



When cleaning the unit, be sure to unplug the power cord, and never handle the plug with wet hands. Electrical shock and/or bodily injury may occur as a result.

1. Cleaning the Unit Surface and Air Quality Sensors

► To clean the unit surface:

- The unit surface should be cleaned at least once a month or sooner depending on the air quality of the room.
- Use a clean, dry cloth to wipe the external surfaces of the air purifier.
- Use a damp cloth to remove stubborn stains and dirt build up if necessary.
- Do not use commercial cleaning agent as it may damage the unit surface.
- Clean the air inlet and outlet with a dry cloth or a vacuum cleaner. (Fig. 1)

► To clean air quality sensors:

- The air quality sensors should be cleaned at least once a month or more depending on the air quality of the room.
- Take off the front panel.
- Clean the surface of the sensor opening with a vacuum cleaner.

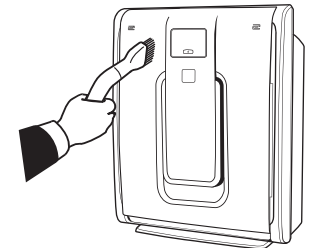

(Fig. 1)

2. Cleaning the Pre-Filter

► To clean the pre-filter:

- The pre-filter should be cleaned at least once a month or when the filter cleaning indicator illuminates.
- After removing the front panel from the air purifier, run a vacuum cleaner with a nozzle or brush attachment on low power setting along the filter to pick up the pet hairs or particles. (Fig. 2)

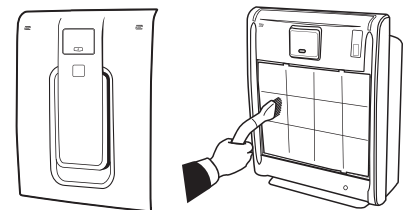

(Fig. 2)

► If your pre-filter appears to have dirt that has not been removed by vacuuming, please follow the steps below to wash the pre-filter.

- Remove the pre-filter from the unit. (Fig. 3)
- Fill the sink with lukewarm water and gently wash the filter under the water for 2-3 minutes or until it is completely clean.
- Rinse the filter with clean tap water.
- Use towel to remove any excess water from the filter.
- Allow the filter to dry for a few hours or overnight.
- When the filter is completely dry, place back into the air purifier.

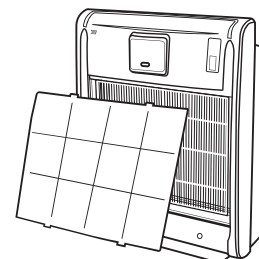

(Fig. 3)

3. Cleaning the BioGP™ HEPA Filter

► To clean the BioGP™ HEPA filter:

- The BioGP™ HEPA filter should be cleaned when the filter cleaning indicator illuminates.
- After removing the pre-filter from the air purifier, run a vacuum cleaner with a nozzle or brush attachment on low power setting along the HEPA filter to pick up the dust and particles (Fig 4).

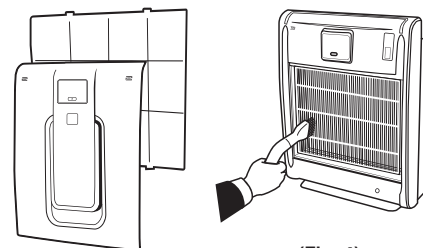

(Fig. 4)

4. Cleaning the Washable Activated Carbon Filter

► To clean the washable activated carbon filter:

- The activated carbon filter should be cleaned when the filter cleaning indicator illuminates.
- Remove the filter from the unit.
- Fill the sink with lukewarm water and add a few drops of mild household detergent (Fig. 5).
- Soak the filter for 10 minutes. Do not leave for an extended period of time.
- Rinse the filter with clean tap water.
- Use towel to remove any excess water from the filter.
- Allow the filter to dry for a few hours or overnight.
- When the filter is completely dry, place back into the air purifier.

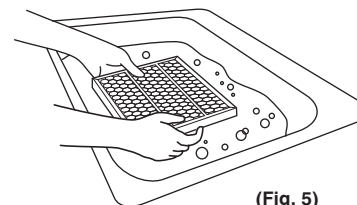

(Fig. 5)

► To reset the Filter Cleaning or Replacement Indicator (🔁)

- Remove front panel.
- With the power on, press and hold the filter reset button for 3-5 seconds, or until the "red" filter cleaning or replacement indicator clears itself (Fig.6).



(Fig. 6)

► Replacing the BioGP™ HEPA filter

- When the filter replacement indicator light comes on, replace the old BioGP™ HEPA filter with a new one.
- To maintain optimum performance of this product, please replace the filters as recommended.
- The air quality and surrounding environment determines the duration and life span of the filter and while it may last longer than expected, it is advisable to change the BioGP™ HEPA filter at least every 18 months or 1.5 year of unit operation.
- The higher the level of pollutants, the shorter the lifespan of the filter.

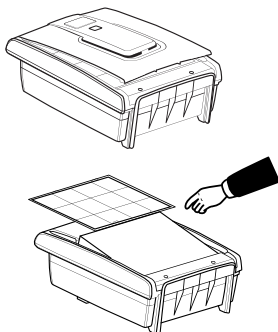

- ① Remove the front cover and the pre-filter
- ② Install a new BioGP™ HEPA filter by following the instructions on step 1 and 2 (page 5).
- ③ After replacing the filter, reset the filter replacement indicator as indicated in page 10.
- ④ Follow the instruction on step 3 (page 5) and complete the filter change.

ATTENTION

Discard the used BioGP™ HEPA filter and do not store for re-use.

For more information on the BioGP™ HEPA filter replacement or to buy replacement filter, please contact Rabbit Air.

► Replacing the washable activated carbon filter

- Replacement indicator light will come on every 18 months, the washable activated carbon filter only need to be replaced every other time when the indicator light comes on. A single filter can last up to 3 years.
- To maintain optimum performance of this product, please replace the filters as recommended.
- The air quality and surrounding environment determines the duration and life span of the filter and while it may last longer than expected, it is advisable to change the washable activated carbon filter every 3 years.
- The higher the level of pollutants, the shorter the lifespan of the filter.

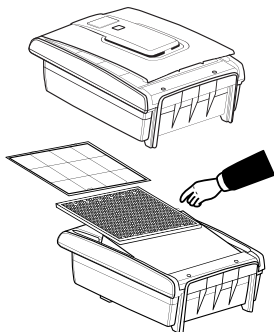

- ① Remove the front cover and the pre-filter
- ② Install a new washable activated carbon filter by following the instructions on step 1 and 2 (page 5).
- ③ After replacing the filter, reset the filter replacement indicator as indicated in page 10.
- ④ Follow the instructions on step 3 (page 5) and complete the filter change.

ATTENTION

Discard the used washable activated carbon filter and do not store for re-use.



BioGP
Ultra Quiet Air Purifier

SPA-421A/582A

LIMITED WARRANTY

Rabbit Air warrants that your BioGP™ Air Purifier will be free from defects in material or workmanship for a period of Five (5) years from the date of purchase. To activate the warranty, please complete and return your warranty registration within 30 days of purchase of your air purifier to Rabbit Air. In order to ensure unit performance, the filters should be replaced with original BioGP™ replacement filters as recommended in this manual (the 'Limited Warranty'). Otherwise the standard warranty time in your country applies.

Within the first 30 days of purchase, Rabbit Air will replace the defective unit at no additional cost and reimburse any shipping charges. After 30 days, Rabbit Air's obligation and liability under this Limited Warranty is limited to repairing or replacing (at its sole discretion) the defective unit. The Limited Warranty does not cover replacement filters.

In the event of a malfunction or failure of your Rabbit Air BioGP™ Air Purifier, please contact Rabbit Air to obtain a return authorization number and the address of the service center. The return authorization number must be clearly written on the outside of the shipping box or the shipment may be refused.

Your Limited Warranty remains in effect only if your BioGP™ Air Purifier:

1. Is operated in accordance with the instruction provided.
2. Is connected to a proper power supply (see voltage label on machine).
3. There is no evidence of tampering, mishandling, neglect, accidental damage, modification, and/or repair done to the BioGP™ Air Purifier by anyone other than authorized BioGP™ service personnel.
4. Your warranty registration has been completed and returned to Rabbit Air.

LIMITS AND EXCLUSIONS

There are no express warranties except as listed above.

THE WARRANTOR SHALL NOT BE LIABLE FOR INCIDENTAL OR CONSEQUENTIAL DAMAGES RESULTING FROM THE USE OF THIS PRODUCT, OR ARISING OUT OF ANY BREACH OF THIS WARRANTY. ALL EXPRESS AND IMPLIED WARRANTIES, INCLUDING THE WARRANTIES OF MERCHANTABILITY, AND FITNESS FOR A PARTICULAR PURPOSE, ARE LIMITED TO THE APPLICABLE WARRANTY PERIOD SET FORTH ABOVE.

Some states do not allow the exclusion or limitation of incidental or consequential damages, or limitation of incidental or consequential damages, or limitations on how long an implied warranty lasts, so the above exclusions or limitations may not apply to you.

This warranty gives you specific legal rights and you may also have other rights which vary from state to state.

If a problem with the product develops during the warranty period, we will repair or replace it without charge to you. A shipping and processing fee may apply. To obtain service under warranty, please contact Rabbit Air at 1-888-866-8862 or by email at products@RabbitAir.com

Troubleshooting

- Before calling for repair, please review the list below. The problem may not be due to unit malfunction.

Symptom	Solution
Unit does not operate.	<ul style="list-style-type: none"> ● Check if power plug is loose. ● Press the main unit control button or any buttons on the remote
The remote control does not work.	<ul style="list-style-type: none"> ● Check if the battery has been depleted. (Refer to P.5) ● Check if the battery is inserted correctly. (Refer to P.5) ● Point the remote control directly towards the main unit display. ● Fluorescent lighting flickering in the room may affect the signal of the remote control. Please service the fluorescent lights.
Odors and smoke are not removed.	<ul style="list-style-type: none"> ● Clean the filters if they appear to be heavily soiled. (Refer to P.9) ● Check if all the plastic bags that wrap the filters are being removed. (Refer to P.5)
The unit does not operate when cigarette smoke is in the air or when the air is highly polluted.	<ul style="list-style-type: none"> ● Check if the unit is installed in a location that is difficult for the sensors to detect the smoke or the air quality. ● Check if the odor or dust sensor openings are blocked or clogged. Clean the sensors (Refer to P.9) ● The unit may not work properly in auto mode because the baseline or reference point is too high. To reset the air quality baseline, unplug the unit and re-insert it in a well-ventilated area.
In auto mode, the unit operates at high speed even when the air is clean.	<ul style="list-style-type: none"> ● The sensitivity of the sensor becomes unstable when the sensor opening is blocked or clogged. Clean the sensors (Refer to P.9). ● Reset the air quality baseline, unplug the unit and re-insert it.
The filter replacement indicator light remains activated even after replacing filter.	<ul style="list-style-type: none"> ● After replacing filters, connect the power cord to an outlet and press the filter reset button on the main unit. ● With the power on, press and hold the filter reset button for 3-5 seconds, or until the "red" filter cleaning or replacement indicator clears itself (Refer to P.10).
The negative ion mode indicator light is flashing.	<ul style="list-style-type: none"> ● Clean the negative ion generator inside the discharge outlet with a vacuum cleaner.

Please do not send products or
other correspondences to this address

First-Class
Postage
Required
Post Office will
not deliver
without proper
postage.



201 West Garvey Ave., Suite 102-168
Monterey Park CA 91754-7418

WARRANTY REGISTRATION FOR

BioGP
Ultra Quiet Air Purifier

RETURN THIS CARD NOW FOR:

● **Product Protection**

With the information you provide we can confirm the date of purchase of your product.
This confirmation is of benefit to you, especially if your original proof of purchase is lost.

● **Proof of Ownership**

Your model number, serial number, and other information will be kept in our files.
Please complete and return this registration within 30 days at purchase in order to receive
your 5 year Limited Warranty.

Or register online at: www.RabbitAir.com

Copyright © 2007 All Rights Reserved
Please fold and seal with tape before mailing. Do not staple.

